



OWNER'S MANUAL

Ver.1.00



WARNING

- For safety reasons, please read the manual first before plugging in machine.
- Please keep this manual properly for convenient reference as needed.

About This Manual

Thank you for purchasing this product.

The manual describes how to install, set up, use and maintain the product. The main purpose of the manual is to instruct how to operate the product correctly and safely. Please follow all the safety and warning instructions in the manual to avoid personal injury and product damage.

This product may only be maintained by a technician. A technician mainly refers to a person who has obtained a certificate of senior middle school related to mechanical engineering, electrical engineering or at a level equal to that of technical senior middle school graduates, and is engaged routinely in the maintenance, management, repair of amusement machine.

When transferring the ownership of this product, be sure to provide this manual with the machine.

For further information about the game and repair (including consumables), please contact our company.

© GuangZhou Wahlap Technology Corporation Limited All Rights Reserved.

Unauthorized reproduction of this document or any of its contents in any form is strictly forbidden.

Table of Contents

About This Manual

1. Safety Precautions.	1
1.1 Warning Stickers	1
1.2 Placing Site	1
1.3 Safety Precautions	2
1.4 Precaution during Play	3
1.5 Transporting and Moving	3
1.6 Installing and Placing	4
1.7 Caution & Warning Stickers	5
2. Product Description.	6
2.1 Product Specification	6
2.2 Overview	7
2.3 Spare Parts	8
2.4 Shipment List	9
2.5 Packing List	12
2.6 Install Direction	13
2.7 Warranty	15
3. Game Description.	16
3.1 Appearance Design	16
3.2 Game introduction	16
3.3 How to play	16
3.4 Connection and turning on the power	17
3.5 Setting the group number and player ID	19
3.6 Motion platform adjustment	20
4. Test and Setting.	21
4.1 Main Menu Operation	21
4.2 Distinctive plays	22
4.2.1 Game control	23
4.3 Operator settings	25
4.4 Using the operator settings	26
4.4.1 Connection status	26
4.4.2 I/O test	27
4.4.3 Force feedback test	28
4.4.4 Lamp test	29
4.4.5 Screen test	30
4.4.6 Speaker test	31
4.4.7 Vibration seat test	31
4.4.8 Keypad test	32
4.4.9 Counter test	33
4.4.10 Air spring test	34

4.5	Game settings	35
4.5.1	I/O adjustment	36
4.5.2	Country	37
4.5.3	Store	37
4.5.4	Difficult setting	38
4.5.5	Tunnel setting	39
4.5.6	Coin setting	39
4.5.7	Multiplayer setting	40
4.5.8	Volume setting	41
4.5.9	Flow time setting	42
4.5.10	Ranking board reset	42
4.5.11	Air spring adjustment	43
4.5.12	Motion default setting	43
4.5.13	Seat belts usage setting	44
4.5.14	Game setting default volume	45
4.6	System settings	46
4.6.1	Connection setting	46
4.6.2	Time setting	47
4.6.3	System reset	48
4.6.4	Player data setting	49
4.7	Income data	50
4.7.1	Daily income	51
4.7.2	Monthly income	52
4.7.3	Total income	53
4.7.4	Income data reset	54
4.8	Troubleshooting	55

5. Maintenance and Service. 56

5.1	Maintenance and service	56
5.2	Part Replacement	57
5.2.1	Maintenance of exhaust pipe and light board	57
5.2.2	Maintenance of the instrument panel LED	58
5.2.3	Maintenance of the instrument panel LED	59
5.2.4	Maintenance of front light board	59
5.2.5	Maintenance of LCD	60
5.2.6	Maintenance of seat lamp	61
5.2.7	Maintenance of host	62
5.2.8	Maintenance of air compressor	62
5.2.9	Maintenance of fluid control valve	63
5.2.10	Maintenance of filter	63
5.2.11	Maintenance of air compressor control board and solenoid valve	64
5.2.12	Maintenance of motor control board and I/O board	64
5.2.13	Maintenance of motion sensor	65
5.2.14	Maintenance of screen light guide	66

6. Assembly	67
6.1 Assembly tree diagram	67
6.2 Top Assembly Drawing	68
6.3 Screen assembly	70
6.3.1 Screen frame assembly	72
6.3.2 LCD assembly	73
6.3.3 Air compressor assembly	74
6.3.4 Transformer assembly	75
6.3.5 Filter assembly	76
6.3.6 Liquid control valve assembly	77
6.3.7 Filter assembly 1	78
6.3.8 Power transformer assembly	79
6.3.9 Host assembly	80
6.3.10 Power amplifier assembly	81
6.3.11 Power box assembly	82
6.3.12 Front light board assembly	83
6.3.13 Screen light guide assembly 1	84
6.3.14 Screen light guide assembly 2	85
6.3.15 Screen light guide assembly 3	86
6.3.16 Screen light guide assembly 4	87
6.3.17 Screen fan assembly	88
6.3.18 Filter assembly 2	89
6.4 Motion platform assembly	90
6.4.1 Motion base assembly	92
6.4.2 Airbag assembly	93
6.4.3 Solenoid valve assembly	94
6.4.4 Sensor assembly	95
6.4.5 Motor assembly	96
6.4.6 Steering wheel light board assembly	97
6.4.7 Bass horn assembly	98
6.4.8 Right console speaker assembly	99
6.4.9 Left console speaker assembly	100
6.4.10 I/O board assembly	101
6.4.11 Motor control board assembly	102
6.4.12 Air compressor control board assembly	103
6.4.13 Control panel assembly	104
6.5 Seat assembly	105
6.5.1 Seat plastic assembly	107
6.5.2 Seat back assembly	108
6.5.3 Safety belt buckle assembly	110
6.5.4 Seat belt assembly	111
6.5.5 Slide rail assembly	112
6.5.6 Exhaust pipe assembly	113

6.6 Left seat cover assembly	114
6.7 Right seat cover assembly	115
6.8 Light box assembly	116
6.9 Rear access door assembly	115
6.10 Console assembly	118
6.10.1 Number button assembly	119
6.10.2 Keypad assembly	120
7.Printing Pattern	121
8.Wiring Diagram	122
9.After-sales Service	

1. Safety Precautions

1.1 Warning Stickers

In order to avoid injury to related people and damage to property, please observe the followings:

PLEASE READ FIRST

- The following marks can be used to indicate the magnitudes of risk and damage caused by ignorance or improper operation:



means “may result in serious injury or death”



means “may result in minor injury or property damage”

Serious Injury: refers to the situations in which hospital treatment or long-term treatment will be accepted because of losing sight, getting hurt, getting burnt, electric shock, fracture or intoxication.

Minor Injury: refers to the cases that there is no need to go to hospital or accept long-term treatment.

Property Damage: refers to the damage of house, facility, or hurt of livestock and pet

1.2 Placing Site

Warning

- please make sure the place line has been grounded before product installation, setup, testing, operation or repair
- This machine is designed for indoor use only. Never install the machine outdoors. Meanwhile, please avoid the following locations indoor:
 - Direct sunlight, water leakage, damp and high temperature places.
 - Near Flammable, volatile, or/and dangerous substance.
 - Slope, unstable places or locations subject to frequent vibration.
 - Near emergency exit, fire extinguisher or similar equipment.
- The rear part has the vent for heat emission from PC or screen. Don't place anything nearby to avoid game failure.
- Provide a space of minimum 30cm between the rear of the machine and the wall for good ventilation and heat emission

1.3 Safety Precautions

The owner shall pay attention to the followings when placing, checking and repairing machine to insure player's security and avoid damage:

Warning

- please check the voltage is 110V or 220V before the machine connects to the power supply, or it may cause a fire or electric shock.
- Make sure to plug the game into 110V or 220V main outlet to avoid fire and electric shock.
- Make sure to turn off the power when performing maintenance and service to avoid electric shock or short circuit.
- Do not unplug or plug the plug instantly.
- Don't touch the power plug with a wet hand to avoid electric shock.
- Don't expose the power cord/grounding line on the passageway. Failure to do this will damage the power cord, causing electric shock or short circuit.
- Don't lay anything near the power cord to avoid fire.
- Do not pull the power cord when unplugging, please hold the plug to avoid power cord damage, causing fire or electric shock.
- In case of power cord damage, please contact the local distributor for replacement
- Only use fuse and spare parts specified by our company
- Connect the connector firmly and tighten the screws.
- Do not dismount, replace or convert the product without our permission in order to avoid damage and human injury due to improper operation.
- Check and maintain the machine regularly.
- Keep "Warning stickers" clean and legible. Replace it immediately when the words are not legible or the dirt can't be removed.
- Please contact our service center when performing any work that is not described in this manual, and follow the instruction provided.

1.4 Precautions during Play

Caution

- In order to avoid injury and accident during play, the following people shall not play the game:
 - People who are injured or less mobile.
 - Person with poor health condition, such as hypertension or heart disease.
 - Person wearing high-heeled or slippery shoes.
 - Person who can't touch the pedal.
 - Pregnant woman, drunk people.
- When a player feels uncomfortable during play, remind the person to have a break, or stop playing.
- Make sure the player reads the warning labels and other indications, and plays in accordance with the instructions to avoid accidents such as electric shock and short circuit.
- Bystander shall not operate any button when the player is playing the game to avoid unnecessary trouble.

1.5 Transporting and moving

Caution

Transporting

- When transporting the machine with an elevator, be sure to employ "Lift Point" to prevent accident and damage to the machine.
- To prevent movement when transporting the machine on a vehicle, please fix the casters and fully retract the adjusters. Failure to do this may cause damage to the machine.
- When carrying the machine with a forklift, be sure to insert the fork to fork position and lift stably. If not, it may cause accident and damage to the machine.
- The glass and LCD screen are fragile. Avoid violent vibration or shock when transporting.

Moving

- Before moving the machine, unplug the power plug to prevent accident. Don't damage the cord.
- Pay attention to the obstructions and uneven surface when moving the machine to prevent accident and damage to the machine.
- Fully retract all adjusters before moving to prevent accident and hazard.
- Make sure to use at least two persons to conduct the above work to avoid accident and injury
- Pay attention to the moving direction, see fig.



1.6 Installing and Placing

Pay attention to the following when placing the machine.

Caution

- Place the machine on the flat and slip resistant area.
- Use the adjusters to fix the machine (See diagram 1)
 1. Loosen the nuts for the adjusters (clockwise), tighten the bolts with a wrench (clockwise).
 2. Tighten the nut firmly (counter clockwise) and fix it well.

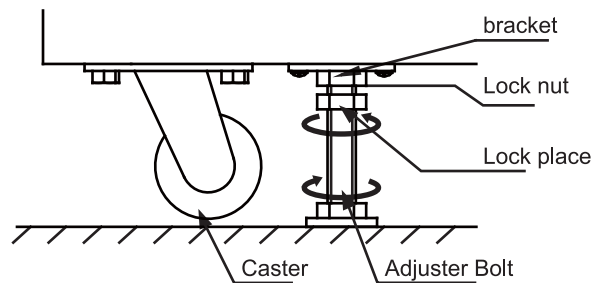

Diagram (1)

- Provide a space of minimum 30cm between the rear of the machine and the wall for good ventilation and heat emission (See diagram 2 and diagram 3).

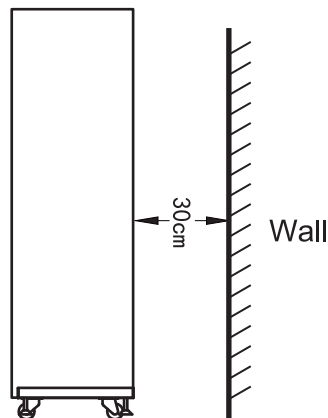

Diagram (2)

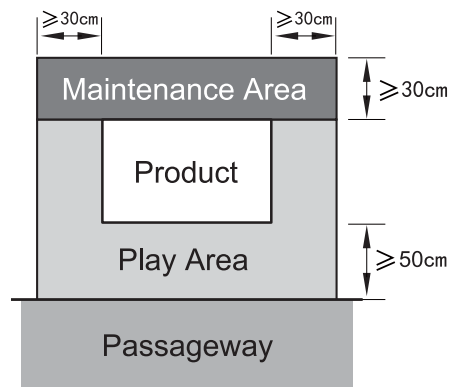
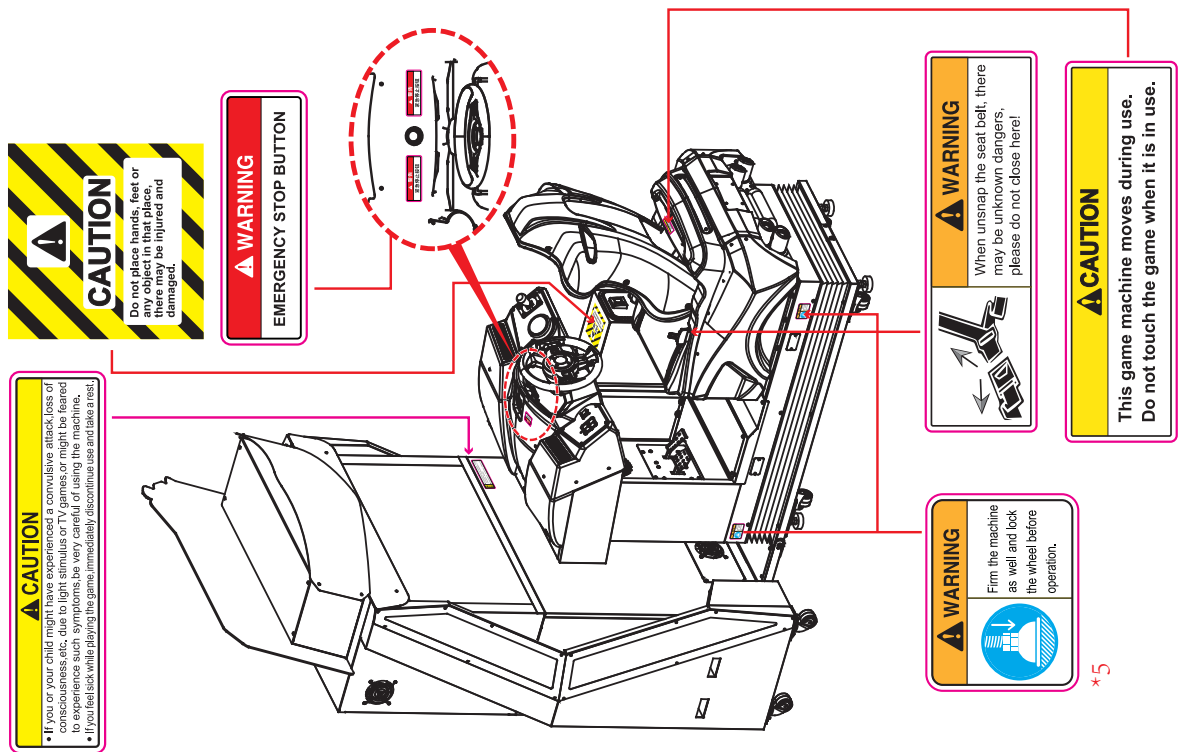
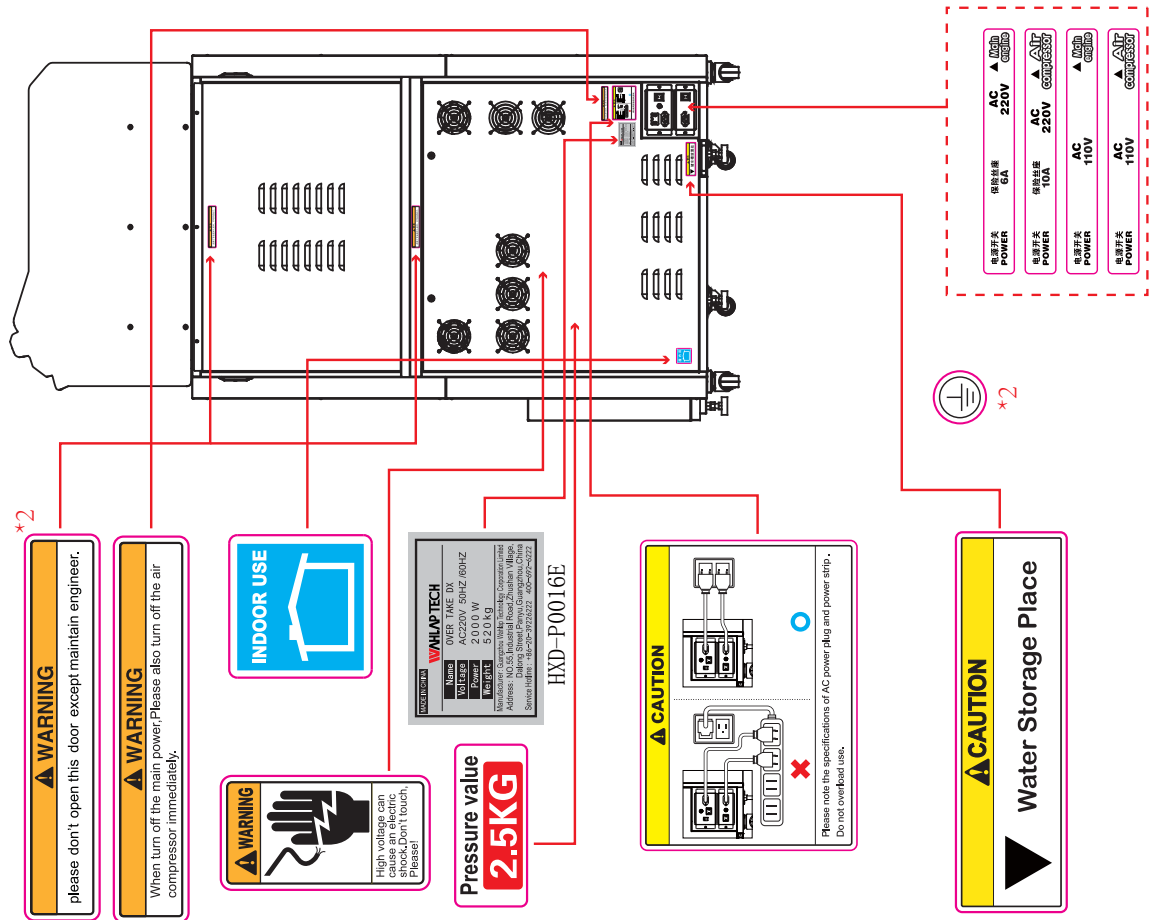

Diagram (3)

1.7 Caution & Warning Stickers



2. Product Description

2.1 Product Specification

■ Location	Indoor Only
■ Dimension	1280(W)×2220(D)×2550(H) mm
■ Rated Voltage、Frequency	AC220V 50HZ /60HZ
	AC110V 50HZ /60HZ
■ Power Consumption	2000 W
■ Weight	520 kg
■ Temperature Range	5~40 °C

*110V voltage can be set through the transformer and fuse. Please contact the distributor for details.

NOTE: The contents herein described are subject to change without notice.

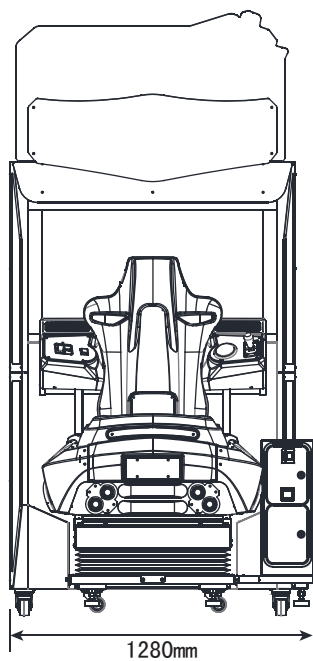

■ Front View

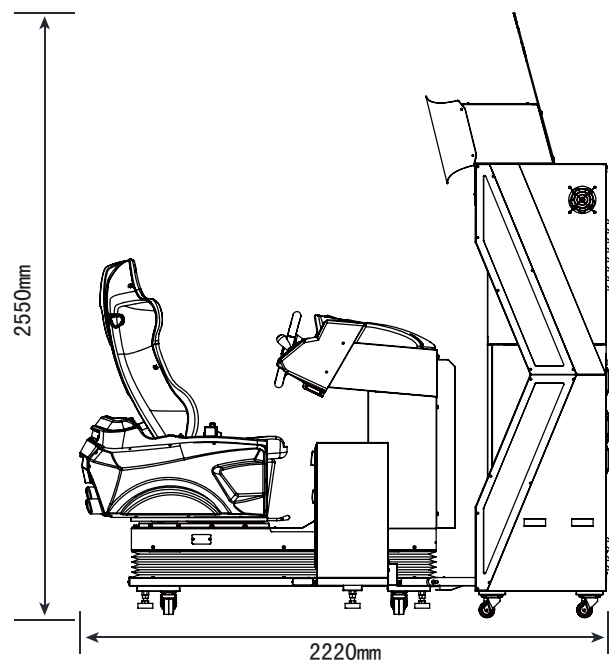

■ Side View

2.2 Overview

■ Side View

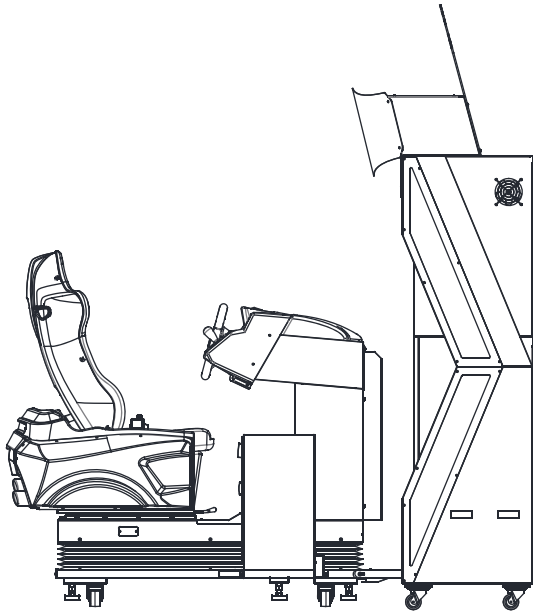

■ Rear View

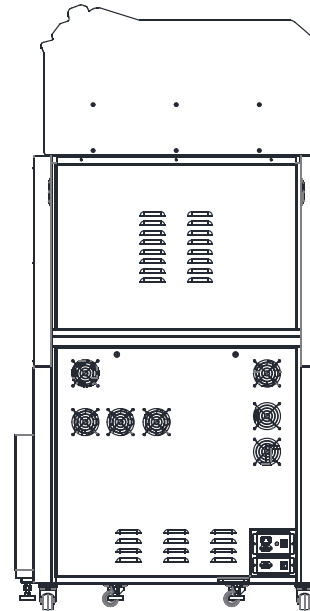

■ Top View

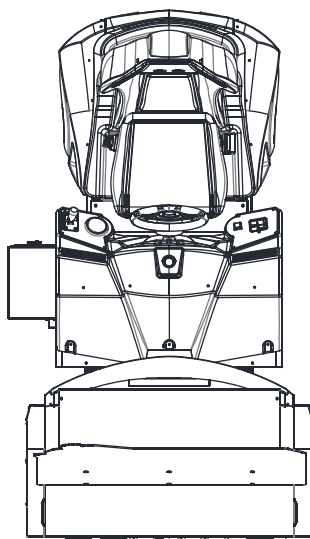

■ Bottom View

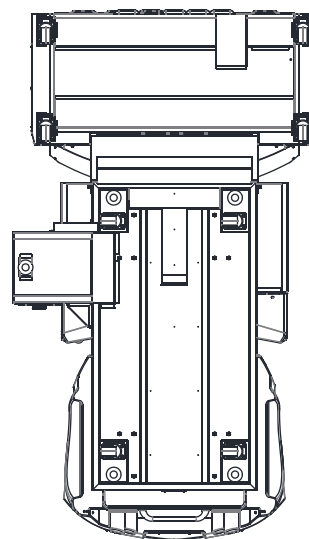

2.3 Spare Parts

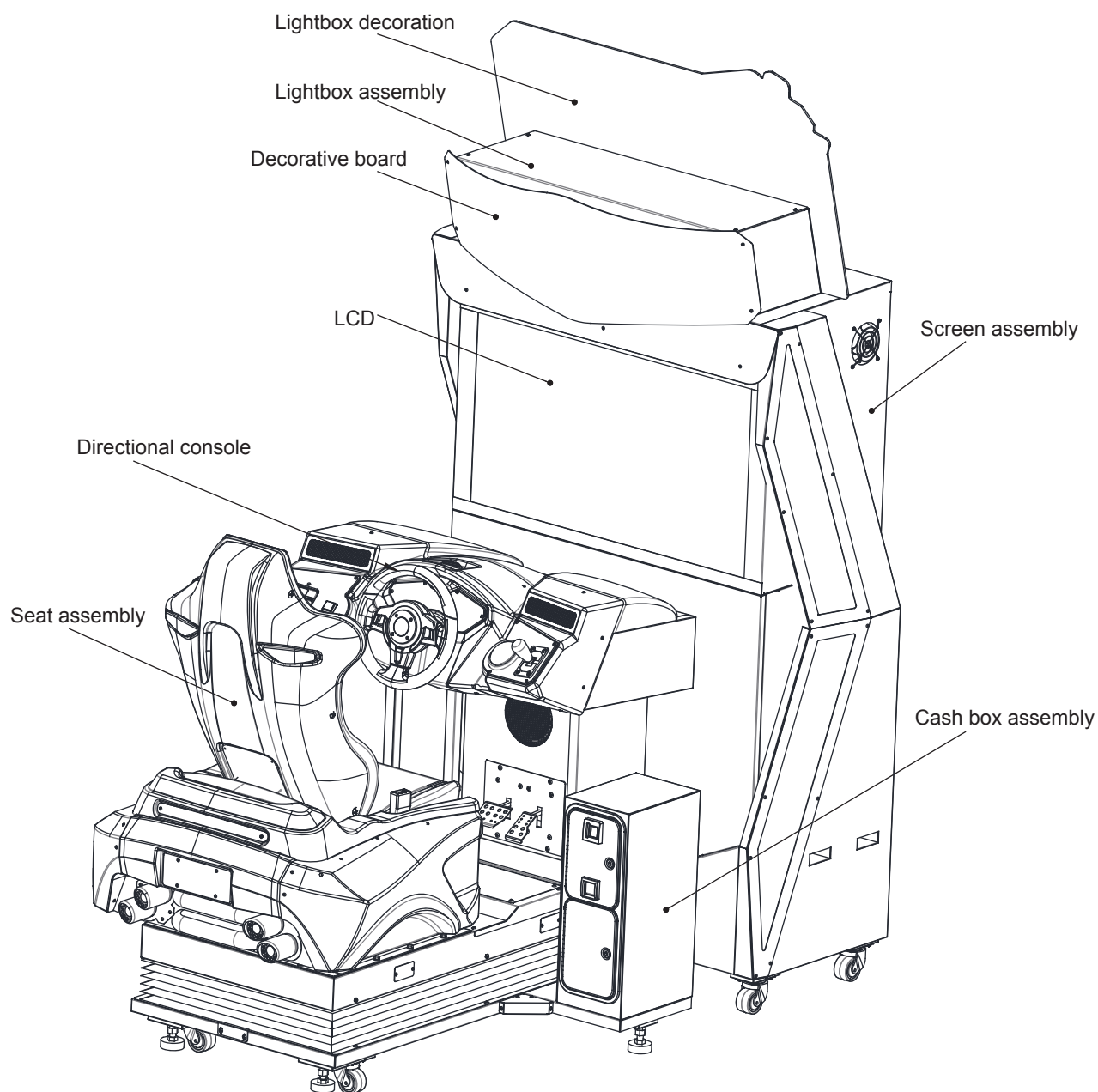

2.4 Shipment List

■ Packing Carton 1

产品名称 Product Name	OVERAKE X
箱体重量 Carton Weight	280 kg
箱体尺寸 Carton Size	1310 x 670 x 2060 mm (W) (D) (H)
箱体备注 Carton Note	荧幕柜细装、背景板、主题装饰
C/NO.	1/3

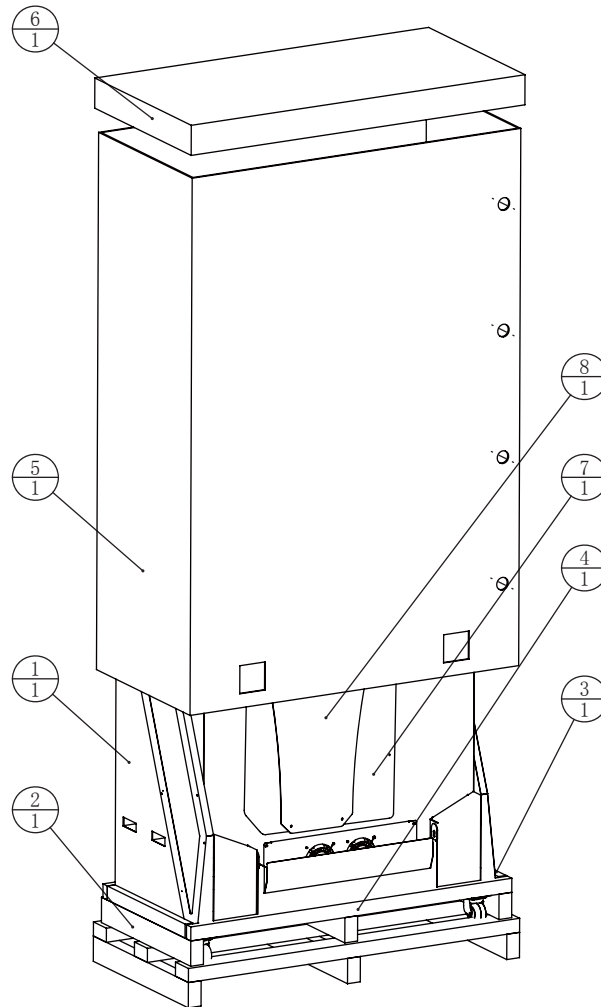

8	HXD-P0005	Decorative board	PVC-2.0T	1	1.7.IG19G00060
7	HXD-P0004	Background trim panel	Andy board-5.0T	1	1.7.IG19G00050
6	HXD-9901E05	A screen	2C 850g T-7	1	1.9.ZX031910
5	HXD-9901E04	Screen enclosure	2C 850g T-7	1	1.9.ZX023880
4	HXD-9901E03	The limit of two wooden screen	wood	1	1.9.MB0235200
3	HXD-9901E02	The limit of wood screen	wood	1	1.9.MB0235190
2	HXD-9901E01	The screen frame platform	wood	1	1.9.MB012340
1		Screen assembly		1	
No.	Draw No.	Name	Material/Spec.	Qty.	Product Code

■ Packing Carton 2

产品名称 Product Name	OVERAGE X	
箱体重量 Carton Weight	275 kg	
箱体尺寸 Carton Dimension	1660 x 1030 x 1650mm (W) (D) (H)	
箱体备注 Carton Remark	座椅组装、钱箱组装、附属品箱	
C/NO.	2/3	共四份装箱单

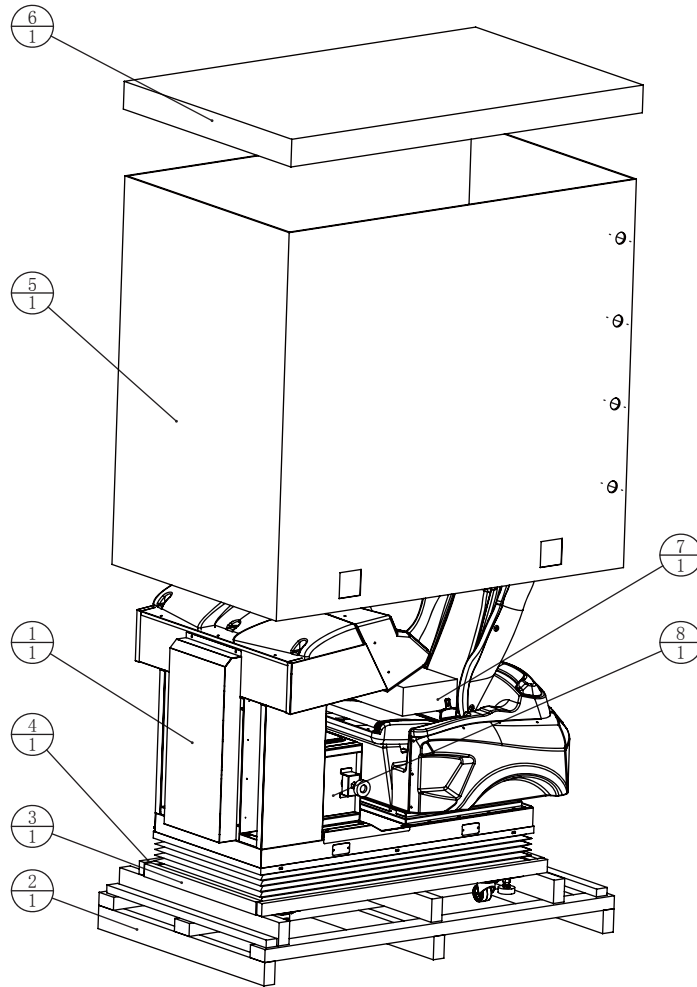

8		Cash box assembly		1	
7		carton		1	
6	HXD-9902E05	A seat	2C 850g T-7	1	1.9.ZX031920
5	HXD-9902E04	Seat frame	2C 850g T-7	1	1.9.ZX023890
4	HXD-9902E03	Seat spacing strips two	wood	1	1.9.MB0235220
3	HXD-9902E02	Seat spacing of wood	wood	1	1.9.MB0235210
2	HXD-9902E01	The seat frame platform	wood	1	1.9.MB012350
1		Seat assembly		1	
No.	Draw No.	Name	Material/Spec.	Qty.	Product Code

■ Packing Carton 3

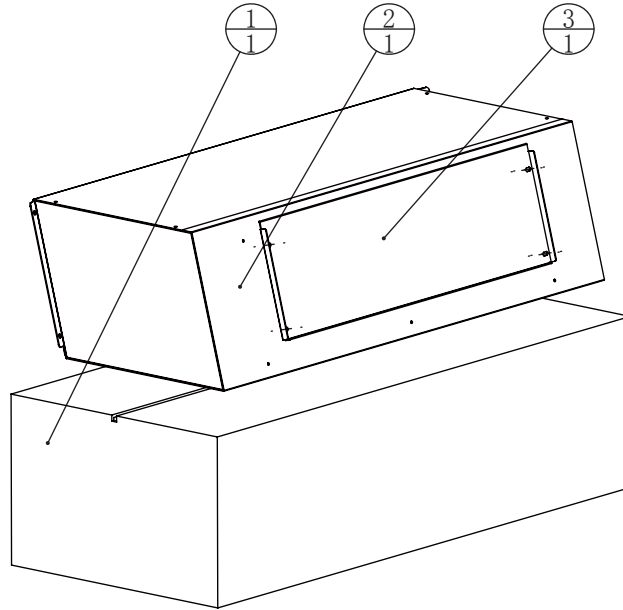

产品名称 Product Name	OVERVIEW X	
箱体重量 Box Weight	20 kg	
箱体尺寸 Box Size	1010 x 430 x 280 mm (W) (D) (H)	
箱体备注 Box Note	灯箱组装	
C/NO.	3/3	多页请翻页

3	HXD-0000A05	Connecting cover plate	SPCC-1.5T	1	1.1.IG19G00050
2		Light box assembly		1	
1	HXD-9903E01	Pop packing carton	K=K	1	1.9.ZX013980
No.	Draw No.	Name	Material/Spec.	Qty.	Product Code

2.5 Packing List

Please check the following items after purchasing our product. If any part missing or damaged, please contact our sales person!

Description	Specification	Quantity	Remarks
key	5555 key	2	
Hex Socket Cap Screws	M4*12 (black)	18	
Plain washers	Φ4*Φ16*1.0 (black)	6	
Cross recessed fillister head three-combination screw	M6*16 (black)	10	
Cross the big flat head screw	M6*12 (black)	3	
Hex Head Cap Screw(BS)	M8*20 (black)	2	
Flat gasket	φ8*φ22*2.0 (black)	2	
Spring washer	M8 (black)	2	
support frame	SPCC-1.5T	1	
Support plate	SPCC-1.5T	1	
Cashbox go line cover		1	Component
component 1	SPCC-1.2T	1	
component 2	SPCC-1.2T	1	
The anchor antiskid rubber pad	Black rubber-8.0T	4	
AC cable	3m (1.0m m ²)	2	
User's manual	Coated paper	1	
Network cable	AMP Gigabit Ethernet cable 5M	1	

2.6 Install Direction

■ Step 1

1. Remove the lightbox. Fix the lightbox decoration and Decorative board at the position shown in the figure using the hexagon flat head screw M4 * 12. Open the back cover of screen. Fix the lightbox assembly using Phillips head trio screw M6*16.
2. Remove the upper two screws of the platform connector. Fix the screen and the seat using these screws. Insert the wire and the connecting cover on the back cover of air pipe. Fix it with hexagon flat head screw M4*12.

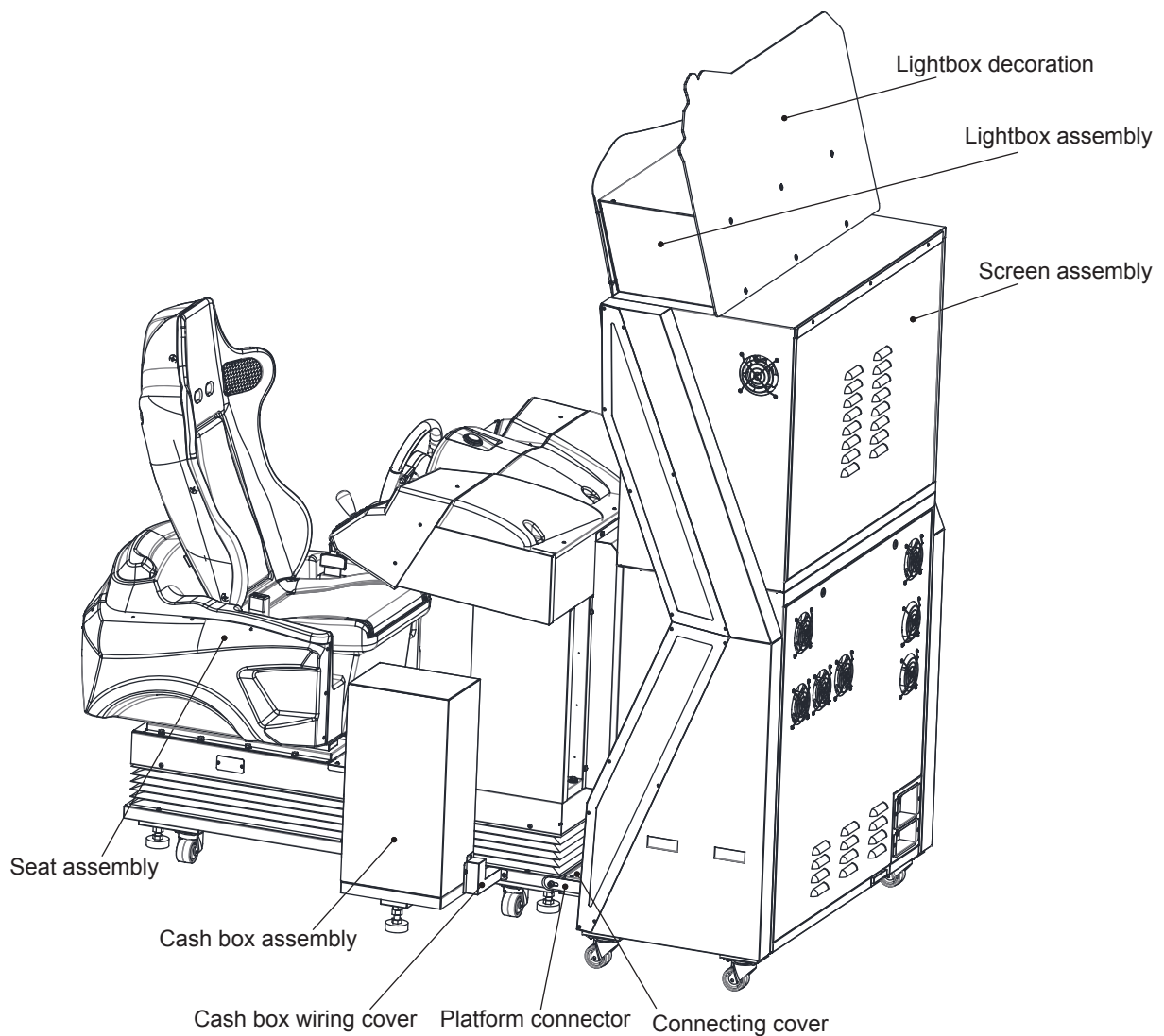

3. Loosen the pedal fixing screw and remove the pedal. Fix the cash box at the position shown in the figure with the hexagon head set screw M8 * 20 (including gaskets and spring washers). Fix the frame using Phillips head trio screws M6*16, and fix the support cover using hexagon flat head screw M4*12, as shown in the figure.
4. Finally, fix the cash box wiring cover using truss Phillips screw M6*12, as shown in the figure. Mount the pedal.

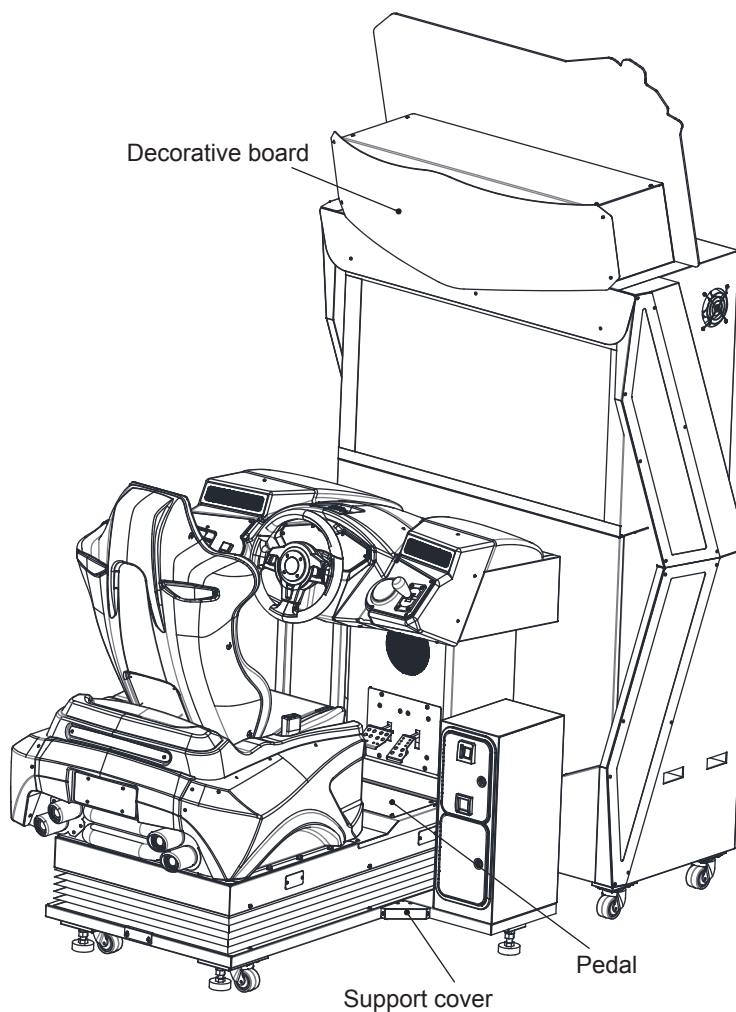

Special attention: When special case occurs in shipment, please check “Installation guide” in attachment box of shipment, and make assembly according to installation guide; special supplement will not be made in this instruction.

2.7 Warranty

■ Scope

- Inquiry regarding product can be assisted for free.
- The warranty scope for consumables and durables may differ from product to product. Please contact our after-sales service center for detailed information. The right of final interpretation is reserved.

■ Exclusive

- Damage caused by force majeure such as god will.
- Failure caused by carelessness, such as water contact, falling down, toppling, knocking.
- Failure caused by disobeying the instructions in this manual.
- Failure caused by operating the machine on inappropriate site.
- Change the original design and configuration for the game without notice.
- Failure to perform regular service and clean.
- Failure to fix the product in line with the manual's requirement.
- Malfunction or part damage caused by electromagnetic interference other electronic equipments generated.

■ Non-warranty Consumables

- Light tube and bulb
- Button lamp and switch
- Fragile items
- Solenoid
- Other spare parts

3. Game Description

3.1 Appearance Design

1. The overall style of the product reflects the sense of speed of the racing, mainly in red/yellow and black. Similar to real manipulating, comfortable seat, and lights reflecting the change to the stadium.
2. The design of the top Kanban focuses on the sense of speed of the racing. Burning flame is chosen to highlight the air flow and heat produced by the speed of the racing, bringing visual impact sense to the bystanders.
3. The arc of the steering wheel and the thickness and pattern of the holding part are designed refer to the real racing. The weight feeling also refers to the real control efforts. Force feedback is designed, so that players can experience real control feeling similar to the racing. The Turbo button is installed inside the steering wheel, which can be operated using the thumb as both hands are holding the steering wheel, greatly enhance the convenience of operation, reflecting the steering feeling of the steering wheel of racing.
4. The seat is designed based on shape and change during moving of the back, waist and hip of the human body, ergonomic and kinematics, more comfortable.
5. The lighting will reflect the changes in the status of the stadium. For example, the lighting will flash for the first player, and change correspondingly during acceleration and braking; combining the eye-attracting blue acrylic lights on both sides, greatly attracting players.

3.2 Game introduction

The RedLine Rush version is an aerodynamic racing game. Six types of popular Ford vehicles can be chosen, with more than a thousand kinds of vehicle modification portfolio, suitable for a variety of scenarios and enjoy of the racing. Three optional game modes brings the player different game experience. Cool shape and aerodynamic function to simulate collision, bumps, steering and acceleration of vehicles, so as to bring players with real experience. The game is also set with data storage capabilities. After each game ends, the vehicle modification and performance is stored. After reading the data before next game, the performance of vehicle of the previous game will continue, adding fun to the game. Up to four-player online battle allows playing with friends and children, improving the versatility of the game.

3.3 How to play

1. Traditional steering wheel + foot, unique turbine speed and perspective button.
2. Wear the seat belt and then put tokens. Choose the game mode, vehicle and track. Then press the Start button (or step on the pedal) to start the game. After the game starts, step on the pedal to play the game. During gaming, press corresponding buttons to increase the effect of games (switching point of view, speed up, JET transform). The remaining route of the player displays at the left of the screen; The game countdown time, player ranking/number of players are displayed at the top of the game screen. The connection status and game time display at the upper right corner of the screen. The nitrogen volume/speed/tachometer/gear/grade, coin information, battle status and other information display at the lower right corner.
3. Strong moving sense during gaming. Fasten the seat belt. Press the emergency stop button at emergency.

3.4 Connection and turning on the power

■ Connecting 2 cabinets

1. Use the key to open the maintenance door located in the back of the cabinet.
2. Plug in one side of the included internet wire to the cabinet and the other side to the router (HUB) .
3. In order to secure connection, do not connect cabinets without connecting the internet wire to the router (HUB)

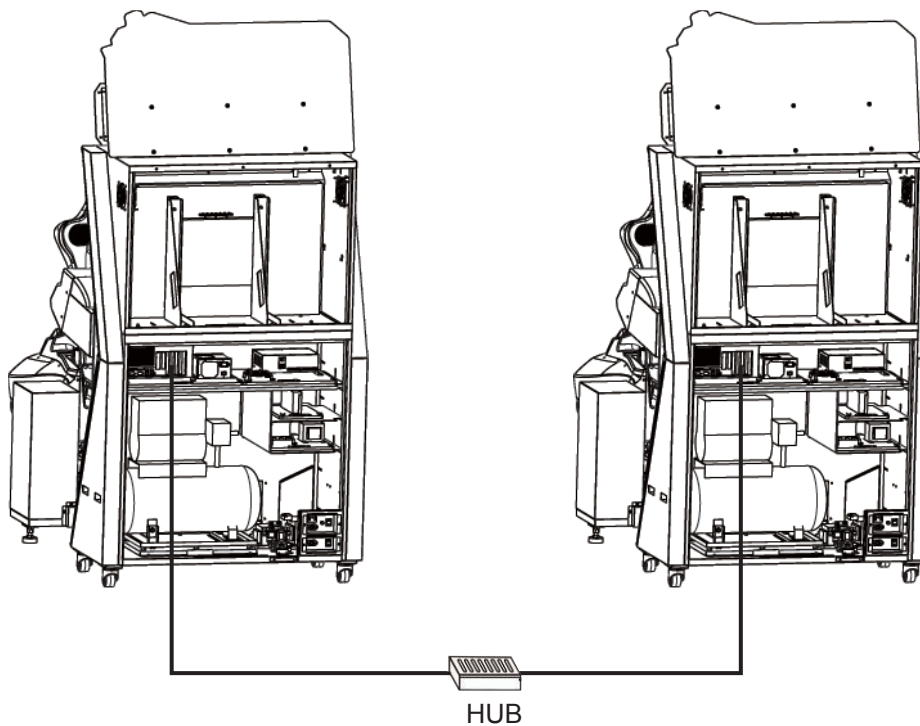

To turn on the cabinet, plug in one side of the included AC cord to the socket labeled as (AC power socket) in the back of the cabinet and the other side to the fused socket.

■ Connecting 4 cabinets

1. Use a key to open the maintenance door located in the back of the cabinet.
2. Plug in one side of the included internet wire to the cabinet and the other side to the router (HUB) .
3. In order to secure connection, do not connect cabinets without connecting the internet wire to the router (HUB) .

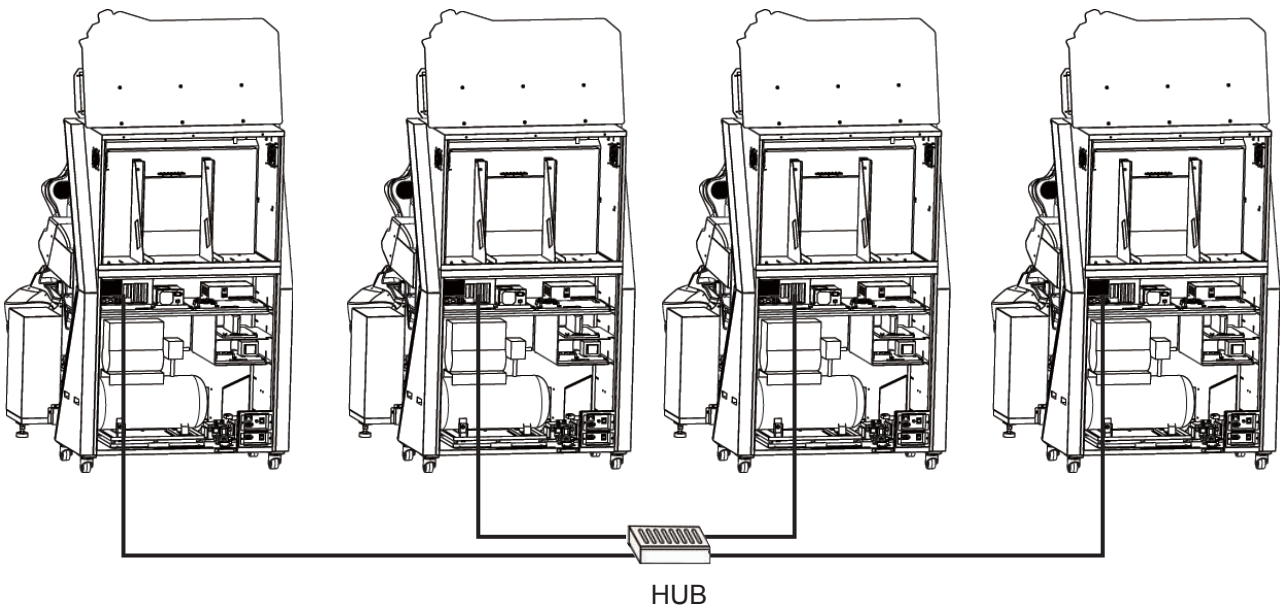

To turn on the cabinet, plug in one side of the included AC cord to the socket labeled as (AC power socket) in the back of the cabinet and the other side to the fused socket.

3.5 Setting the group number and player ID

In order to launch a multi-player mode (a maximum of 4 cabinets is allowed) , you must assign the cabinets into the same group number but different player ID. If 4 cabinets are connected, then appoint their player ID as 1P, 2P, 3P, 4P.

1. Under the stand by mode, open the coin box, and press the **【Test】** button to enter **【Operator settings】** .
2. Enter **【Operator settings】** → **【System setting】** → **【Connection setting】** .



3. Assign the cabinets into the same group but different player ID.
Example of setting up the connection of 2 cabinet (viewed from the front of the cabinet) :



Example of setting up the connection of 4 cabinets (viewed from the front of the cabinets) :

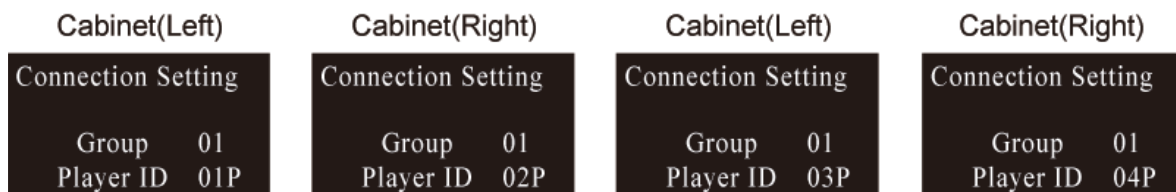

After completing all setups, you cloud enter **【Operator settings】** → **【Hardware test】**
→ **【Connection status】** to test whether it is well connected or not.
(Details refer to 4.4.1 Connection status)

3.6 Motion platform adjustment

In order to launch motion platform in the game, you must process the air spring adjustment when the machine is first time start up or after system has been reset.

- 1.Under the standby mode, open the coin box, and press the **【Test】** button to enter **【Operator Settings】** .
- 2.Enter **【Operator settings】** → **【Game settings】** → **【Air spring adjustment】** .

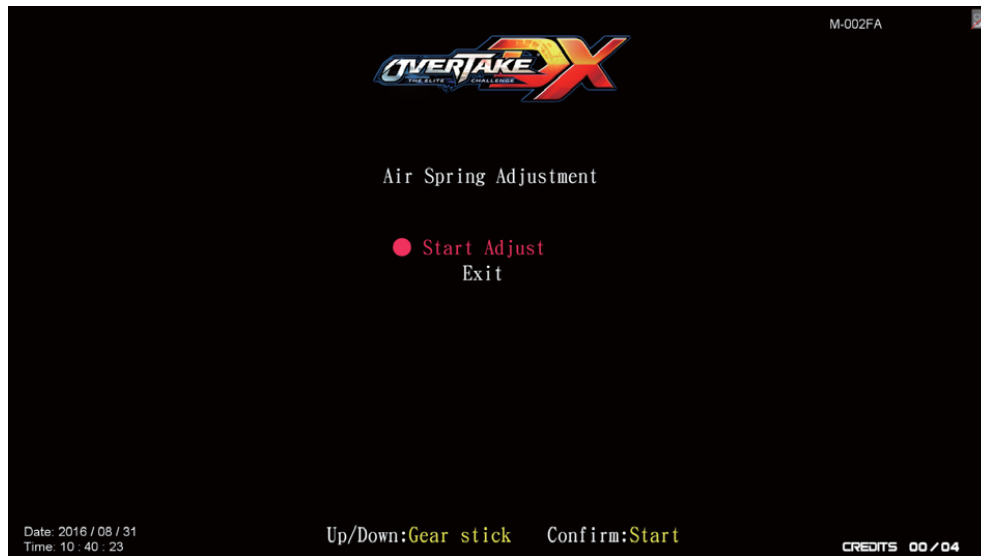

- 3.Use **【Gear up】** and **【Gear down】** to move the cursor to the **【Start adjust】** and press **【Start】** button to start adjustment.
- 4.After the adjustment is completed, move the cursor to the **【Exit】** and then press **【Start】** button to exit the **【Air spring adjust】** .

Warning

The motion platform will not be function right or malfunction if the adjustment is not complete.

4. Test and Setting

4.1 Main Menu Operation

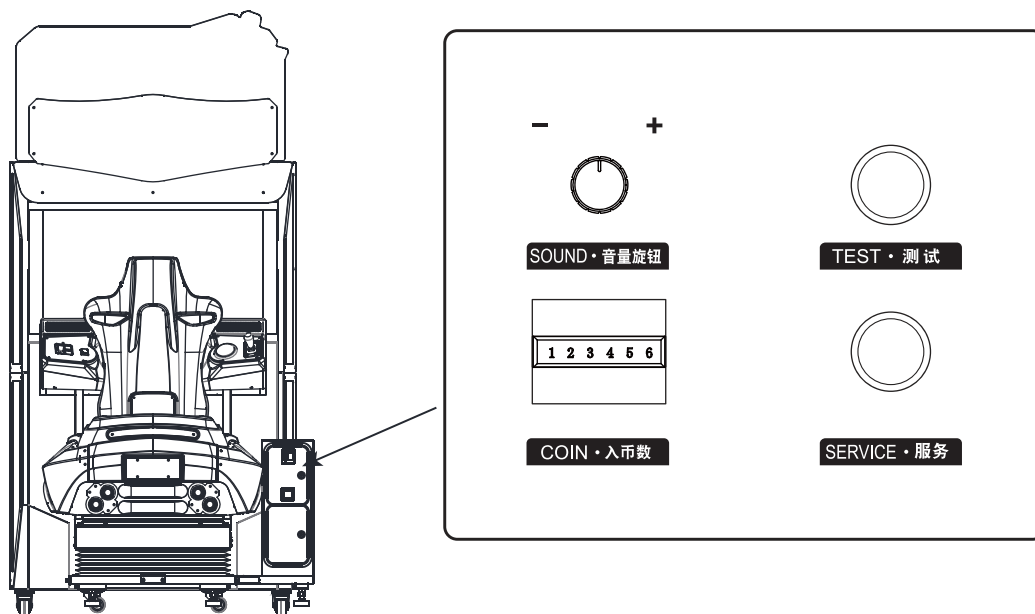

Volume: adjust the volume

Test: enter into the test mode.

Coin: coin counting.

Service: you can input the available service-points without increasing their tokens.

4.2 Distinctive plays













- Three game modes
 - Multi-player mode: a maximum of 4 players is allowed.
 - Race mode: to challenge each round and upgrade the vehicle.
 - Time trial: to challenge the best record on the track.



- Six fusion vehicles.
- Thousands of modification combinations.
- Be equipped with the newest vibration chair and force feedback system of the steering wheel.
- Boost and Turbo Jet could enhance the vehicle's speed and reach its ultimate speed.
- Total of 12 themed scenes including cities, roads, Arctic, etc...
- Random track combinations and events.

4.2.1 Game control

Except the basic operations such as speeding and stepping on the brake, other operations are as follows:

<p>1. Press  to confirm. This button can also provide boost; when pressed twice, Turbo Jet will be initiated.</p>	
<p>2. Turning the steering wheel to the left or right could make turns.</p>	
<p>3. When the game is in process, press  to change view point.</p>	
<p>4. When the game is in process, and  occurs, press the button to avoid event.</p>	
<p>5. When the manual transmission is selected, use the gear stick to change gears.</p>	
<p>6. When the game is in process, press  and  at the same time to end the game. (This function does not work under multiplayer mode) .</p>	

■ Instructions of the control buttons



■ Instruction of the game display



4.3 Operator settings

Framework of the menu

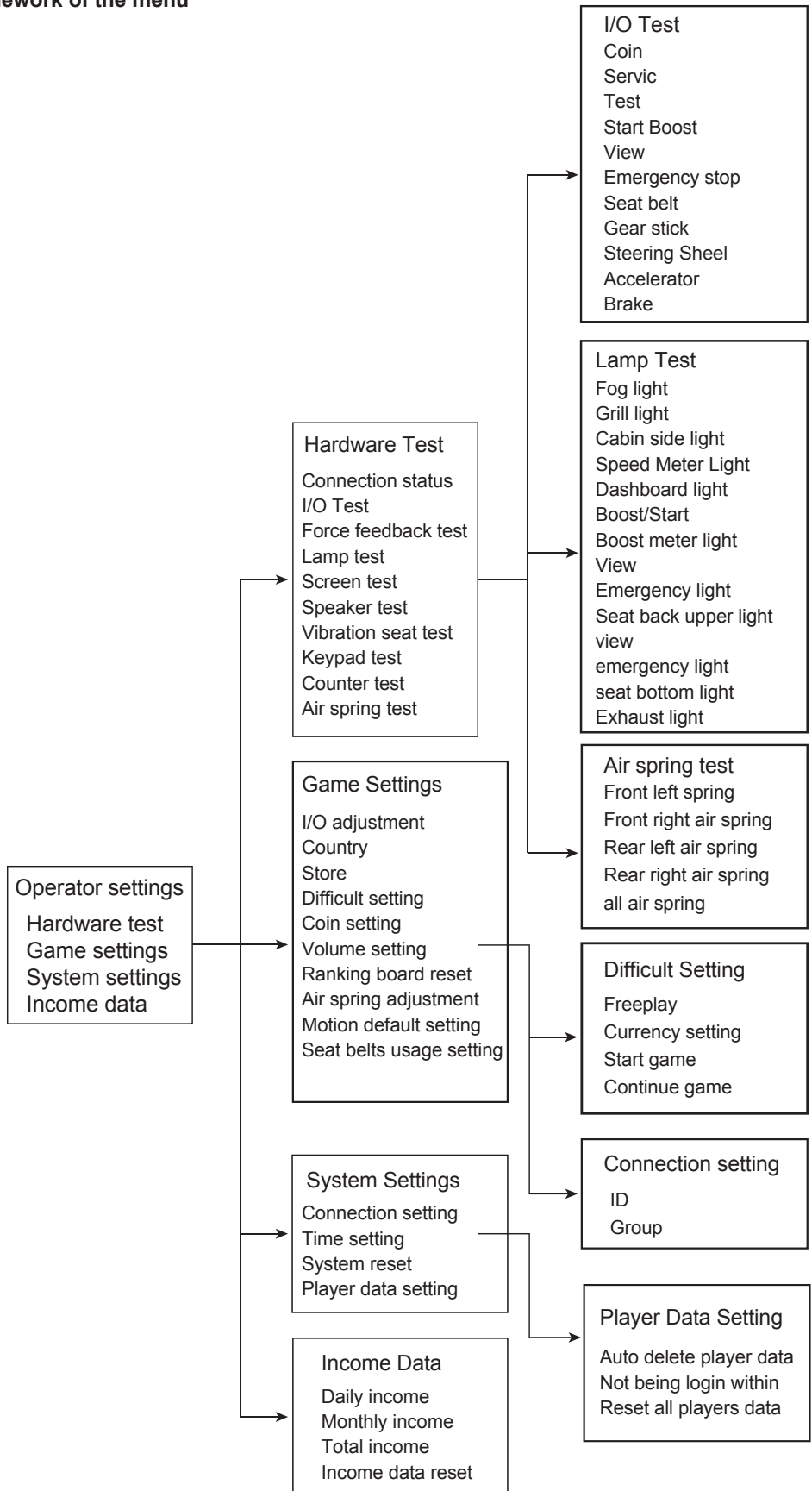

4.4 Using the operator settings

Make sure the cabinet is turned on and the game is displayed on the screen.

1. Open the door of the coin box and press the **【Test】** button to enter operator settings, the screen will display as below:

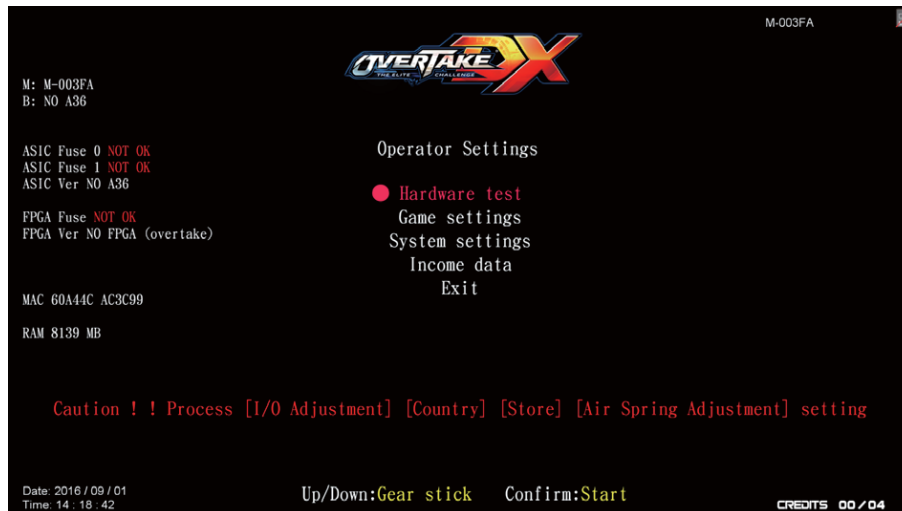

Enter the menu and follow the instructions.

2. Use the **【Gear up】** and **【Gear down】** functions on the gear stick move the cursor, and the item where the cursor is pointed to will appear in red.
3. Use the **【Start】** button to confirm or enter the sub menu.
4. After setup or testing is completed, return to **【Operator settings】** and move the cursor to **【Exit】** . then press the **【Start】** button to return to the game.

Note: When warning message appear as: Caution!! Process **【I/O adjustment】 【Country】 【Store】 【Connection】 【Air spring adjustment】** setting. Please process the following setting before exit operator settings.

4.4.1 Connection status

In the page of **【Connection status】** , you can check the connection status of this cabinet.

1. Enter **【Operator settings】** → **【Hardware test】** → **【Connection status】** and the screen will display as below:

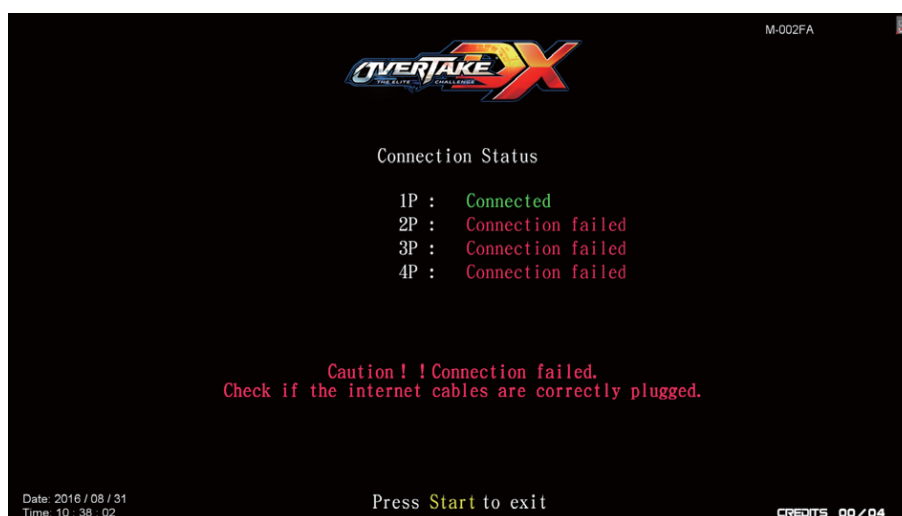

2. Press the **【Start】** button to leave this page and return to **【Hardware test】** .

4.4.2 I/O test

In the page of **【I/O test】** , you can run the testing of specific application to see if it is normally functioning or not. well-sensed devices will be show with a corresponding picture, value or "on" icon.

1. Enter **【Operator settings】** → **【Hardware test】** → **【I/O Test】** , and the screen will display as below:

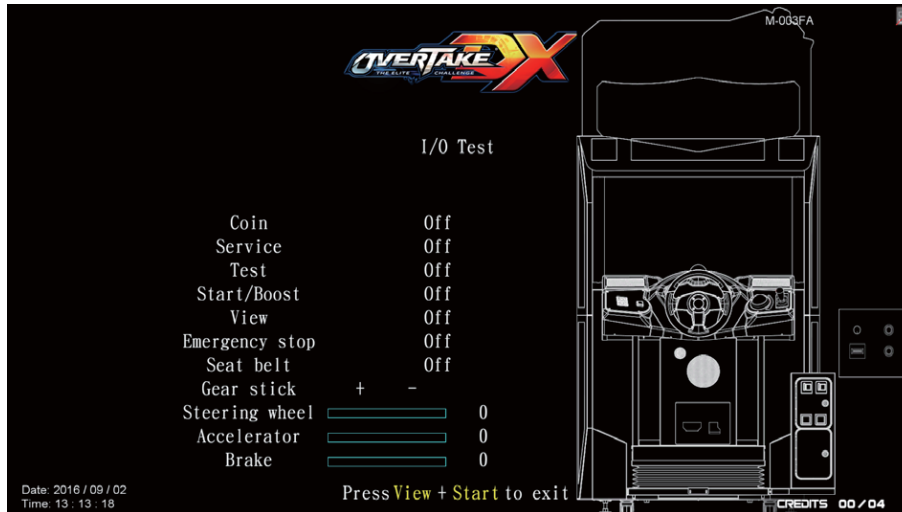

2. After you enter the page of **【I/O test】** , you can run the testing of a specific application as explained in the chart below:

Applications	Testing method	Result
Coin	Insert coins	"Off" became "On"
Service	Press the button	"Off" became "On"
Test	Press the button	"Off" became "On"
Start / boost	Press the button	"Off" became "On"
View	Press the button	"Off" became "On"
Emergency stop	Press the button	"Off" became "On"
Seat belt	Fasten seat belt	"Off" became "On"
Gear stick	Shift the gear up and down	Corresponding icons "+" or "-" will appear as red
Steering wheel	Turn the steering wheel to the right and left	When the steering wheel is turning to the left or the right, the corresponding status and value will be around -1 or 1.
Accelerator	Step on the throttle	When the throttle is release the corresponding status and value will be 0, and when being stepped on it, the value will be around 1.
Brake	Step on the brake	When the brake is release the corresponding status and value will be 0, and when being stepped on it, the value will be around 1

3. After testing is completed, press the **【View】** and **【Start】** buttons to leave this page, and return to **【Hardware test】** menu.

Note: If the values of the throttle, brake and steering wheel are abnormal, enter **【I/O adjustment】** to make adjustments

4.4.3 Force feedback test

In the page of **Force feedback test** , you can test whether the force feedback is normally functioning or not.

1. Enter **Operator settings** → **Hardware test** → **Force feedback test** , and the screen will display as below :



2. Use the **Gear up** and **Gear down** functions on the gear stick to move the cursor, and choose the **Steering wheel** , then press the **Start** button to run testing.
3. While testing, press the **Start** button one more time to discontinue the testing process.
4. After the testing is completed, move the cursor to **Exit** and press the **Start** button to return to **Hardware test** .

4.4.4 Lamp test

In the page of **【Lamp test】** , you can test if each light is normally function or not.

1. Enter **【Operator settings】** → **【Hardware test】** → **【Lamp test】** , and the screen will display as below:

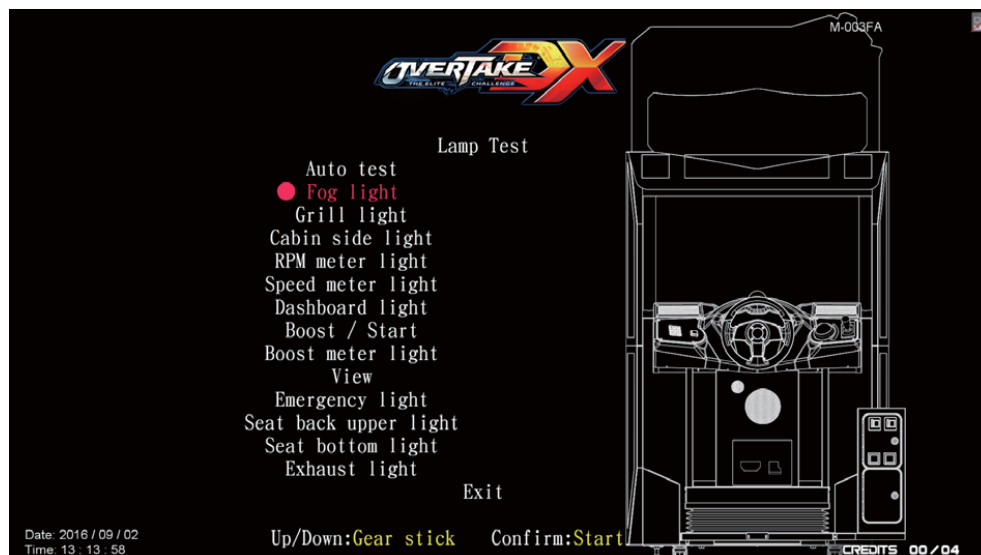

2. Use the **【Gear up】** and **【Gear down】** functions on the gear stick to move the cursor, and choose the lamp to be test, then press the **【Start】** button to run testing.

Fog light / Dashboard light / View / Emergency light / Seat back upper light / Exhaust light: Blink five times.

Grill light / Cabin side light / RPM meter light / Speed meter light / Boost / Boost meter light / Seat bottom light: Three kinds of RGB light will blink five times.

3. While testing, press the **【Start】** button one more time to discontinue the testing process.
4. After testing is completed, move the cursor to **【Exit】** , and press the **【Start】** button to return to **【Hardware test】** .

4.4.5 Screen test

In the page of **【Screen test】** , you can test whether the white balance, color level, and lattice are normally functioning or not.

1. Enter **【Operator settings】** → **【Hardware test】** → **【Screen test】** .
2. After you enter the page of the **【Screen test】** , the system will then process the testing, and the following six pictures will be displayed for you to adjust the white balance, color level, and lattice.

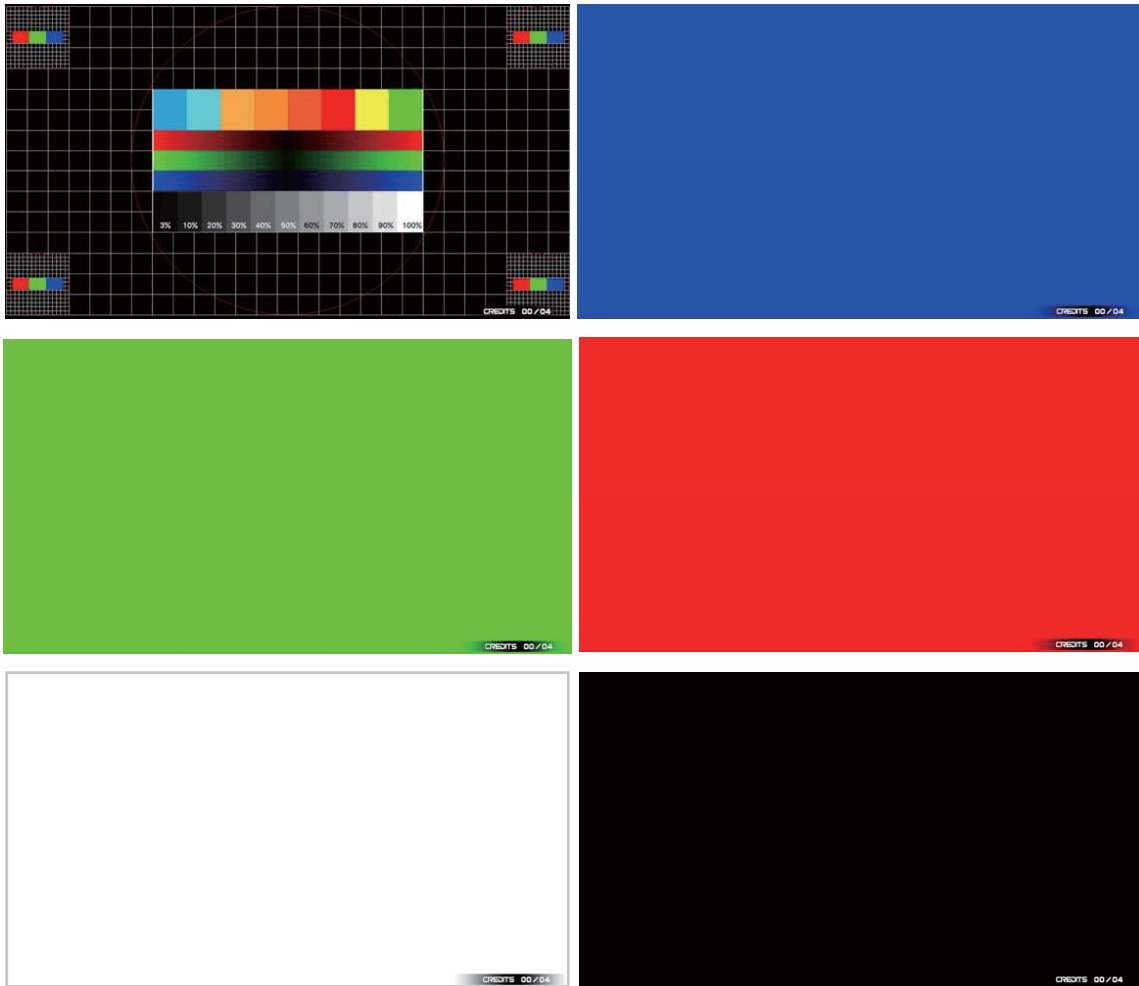

4.4.6 Speaker test

In the page of **【Speaker test】** , you can test whether the loudspeaker is normally functioning or not.

1. Enter **【Operator settings】** → **【Hardware test】** → **【Speaker test】** , and the screen will display as below :

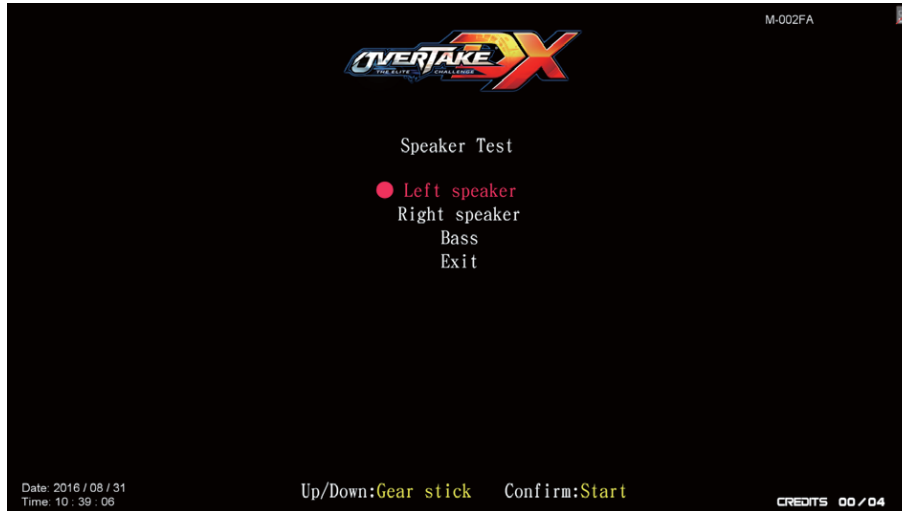

2. Use the **【Gear up】** and **【Gear down】** functions on the gear stick to move the cursor, and choose the soundtrack to be tested, then press the **【Start】** button to start testing.
3. The soundtrack being tested will keep producing a certain sound, and press the **【Start】** button to discontinue the testing process.
4. After the test is completed, move the cursor to **【Exit】** , and press the **【Start】** button to return to **【Hardware test】** .

4.4.7 Vibration seat test

In the page of **【Vibration seat test】** , you can test whether the vibration chair is normally function or not.

1. Enter **【Operator settings】** → **【Hardware test】** → **【Vibration seat test】** , and the screen will display as below :

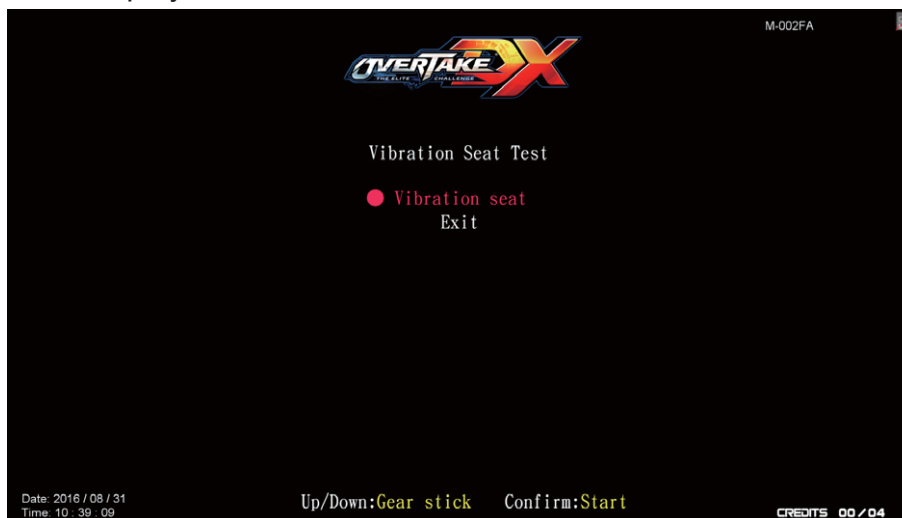

2. Use the **【Gear up】** and **【Gear down】** function on the gear stick to move the cursor, and choose the **【Vibration seat test】** , then press the **【Start】** button to start testing.
3. The seat being tested will keep producing with a certain vibration, and press the **【Start】** button to discontinue the testing process.
4. After the testing is completed, move the cursor to **【Exit】** , and press the **【Start】** button to return to **【Hardware test】** .

4.4.8 Keypad test

In the page of **【Keypad test】** , you can test whether the keypad is normally functioning or not.

1. Enter **【Operator settings】** → **【Hardware test】** → **【Keypad test】** , and the screen will display as below :



2. Then press keypad key to test the key is normally function or not.
3. After the testing is completed, press **【Start】** button to exit return to **【Hardware test】** menu.

4.4.9 Counter test

In the page of **【Counter test】** , you can test whether the counter is normally functioning or not.

1. Enter **【Operator settings】** → **【Hardware test】** → **【Counter test】** , and the screen will display as below :



2. After you enter the page of **【Counter test】** , insert coins to the coin slow, and the number on the right will goes up as more coins are inserted. also, the counter inside the coin counter will indicate the number too.
3. After testing is completed, press **【Start】** button to return to **【Hardware test】** .

4.4.10 Air spring test

In the page of **【Air Spring test】** , you can test whether the air spring is function or not.

1. Enter **【Operator setting】** → **【Hardware test】** → **【Air spring test】** , and the screen will display as below :

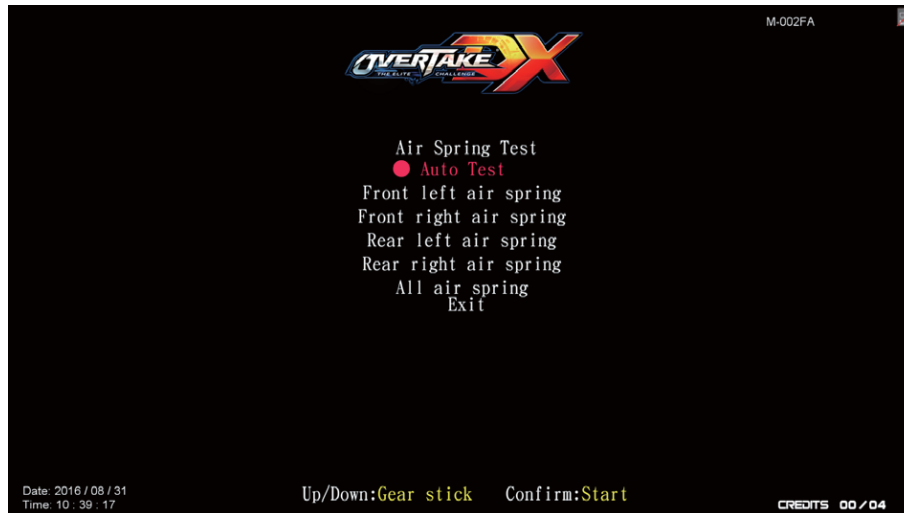

2. Use **【Gear up】** and **【Gear down】** to move the cursor and then press the **【Start】** button to test the air spring on the cursor you have selected.
3. While testing, press the **【Emergency stop】** button will stop the test.
4. When the **【Emergency stop】** has been activate, the warning message will be appear as “※Motion platform: The emergency stop has been activated, press the“Emergency stop”button to deactivate the emergency stop.”
5. After the testing is completed, move the cursor to **【Exit】** and press the **【Start】** button to return to **【Hardware test】**

4.5 Game settings

In the page of **【Game settings】** , you can set up all related features of the game.

1. Enter **【Operator settings】** → **【Game settings】** , and the screen will display as below:

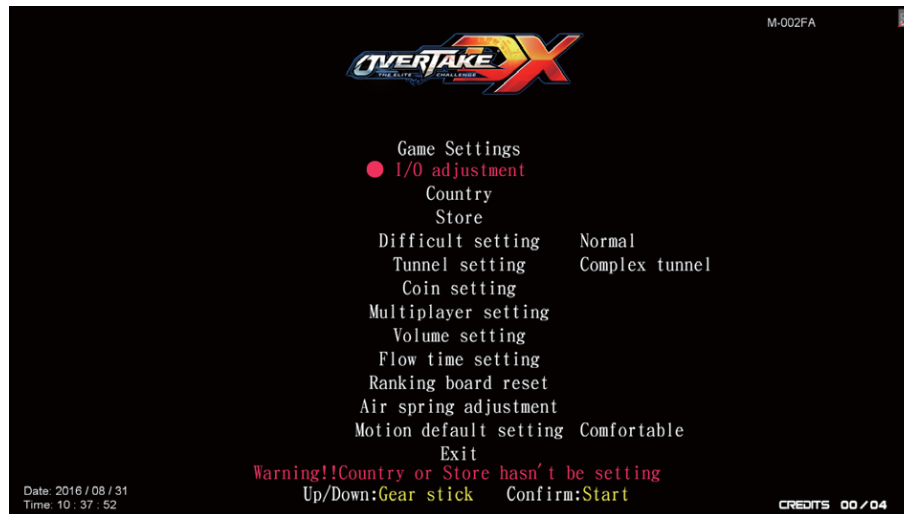

2. Use the **【Gear up】** and **【Gear down】** functions on the gear stick move the cursor, and the item where the cursor is pointed to will appear in red.
3. Use the **【Start】** button to confirm or enter the sub menu.
4. After setup is completed, move the cursor to **【Exit】** , and press the **【Start】** button to return to **【Operator settings】** .
5. Regarding the detailed description of the sub menu in the **【Game settings】** , refer to the following content.

4.5.1 I/O adjustment

In the page of **I/O adjustment** , you can adjust the minimum and maximum value of the throttle, brake and steering wheel.

1. Enter **Operator settings** → **Game settings** → **I/O adjustment** , and the screen will display as below:

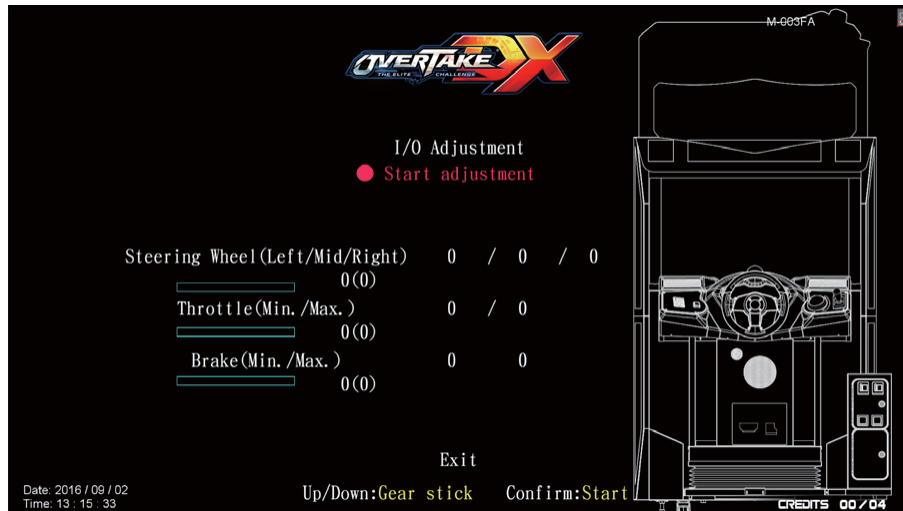

2. Enter the page of **I/O adjustment** , and move the cursor to **Start adjustment** , then press the **Start** button to start the process.
3. While adjusting, turn the steering wheel to the left end, and press the **Start** button to get the value.
4. Repeat the above step, and calibrate other values.
5. After all adjustments are made, an icon of **Adjustment completed** will pop up, then press the **Start** button to return to **Game settings** .

4.5.2 Country

In the page of **Country** , you can set your current location.

1. Enter **Operator settings** → **Game settings** → **Country** , and the screen will display as below:



2. Use the **Gear up** , **Gear down** , **Steering wheel** functions to move the cursor, and the item where the cursor is pointed to will appear in red. When the country has been chosen then press the **Start** button to confirm and return to the page of **Game settings** .
3. The country you selected will be shown next to the **Country** .

4.5.3 Store

In the page of **Store** , you can set up the name of your store.

1. Enter **Operator settings** → **Game settings** → **Store** , and the screen will display as below:

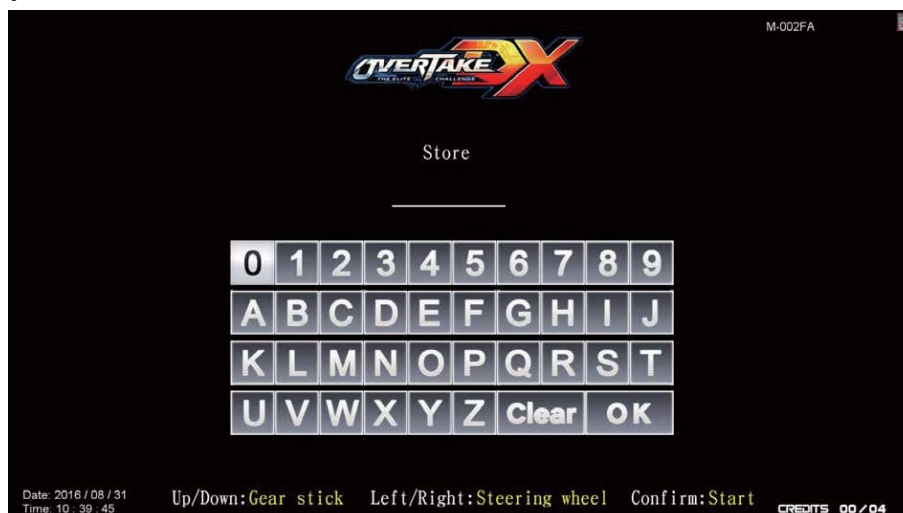

2. Use the **Gear up** , **Gear down** , **Steering wheel** functions to move the cursor, and press the **Start** button to confirm the letter you want to input. When completed, move the cursor to **OK** then press the **Start** button to return to the page of **Game settings** .
3. The store name you typed will be shown next to the **Store** .

4.5.4 Difficult setting

In the page of **【Difficult setting】** , you can set up your preferred level of difficulty for the game.

1. Enter **【Operator settings】** → **【Game settings】** → **【Difficult setting】** , and the screen will display as below :

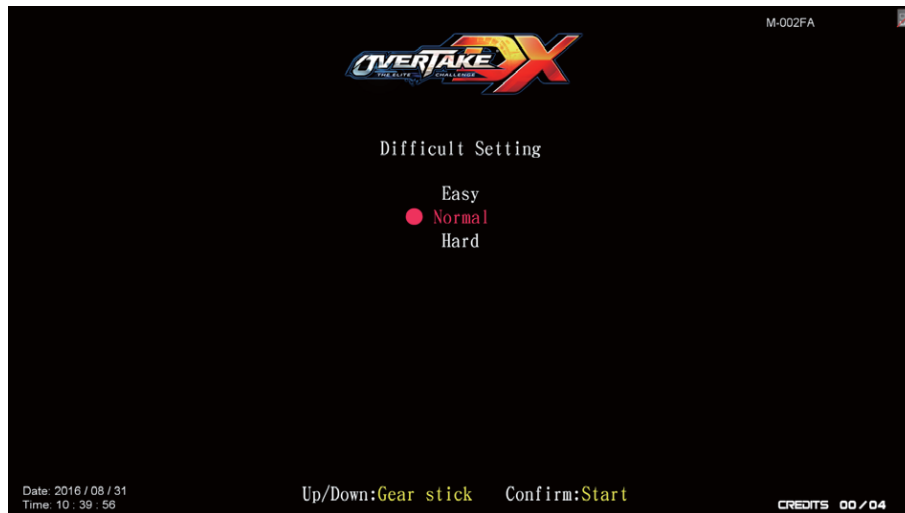

2. Use the **【Gear up】** and **【Gear down】** function on the gear stick to choose the level of difficulty.
3. After you preferred level is chosen, press the **【Start】** button, and return to **【Game settings】** .
4. The level chosen will be shown next to the **【Difficult setting】** .

Warning To avoid errors, make sure the difficult setting of all cabinets are the game.

4.5.5 Tunnel setting

In the page of **【Tunnel setting】** , you can set up the tunnel for complex tunnel or straight tunnel only.

1. Enter **【Operator settings】** → **【Game settings】** → **【Tunnel setting】** , and the screen will display as below :

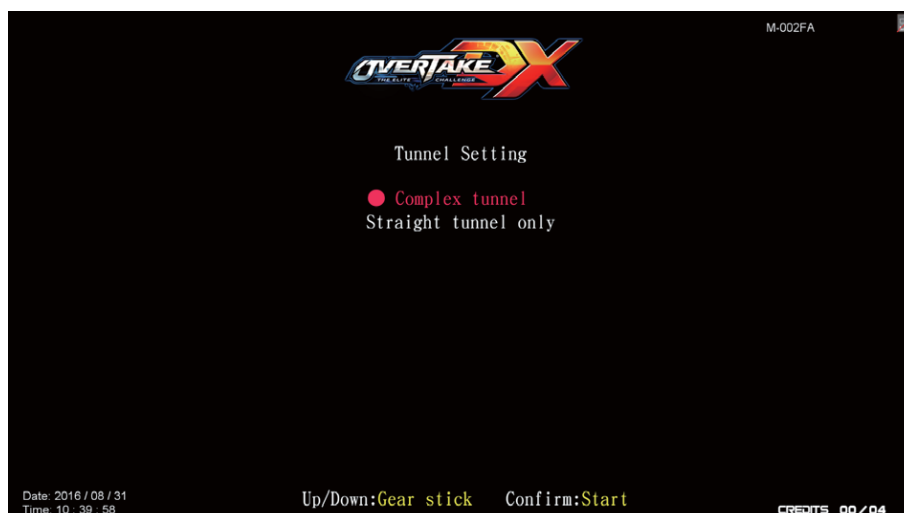

2. Use the **【Gear up】** and **【Gear down】** function on the gear stick to choose the setting.
3. After you preferred setting, press the **【Start】** button, and return to **【Game settings】** .
4. The setting chosen will be shown next to the **【Tunnel setting】** .

4.5.6 Coin setting

In the page of **【Coin setting】** , you can determine if free games are offered, or set up the require number of coins to start or continue a game.

1. Enter **【Operator settings】** → **【Game settings】** → **【Coin setting】** , and the screen will display as below :

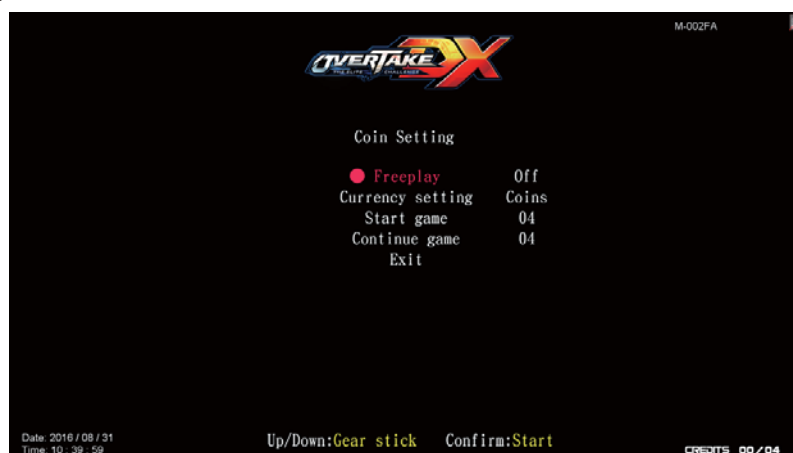

2. Use the **【Gear up】** and **【Gear down】** functions on the gear stick to choose the item, then press the **【Start】** button to start the process.
3. When the settings is completed, move the cursor to **【Exit】** , and press the **【Start】** button to return to **【Game settings】**

Note When the **【Freeplay】** is set to be **【On】** , the **【Start game】** and **【continue game】** cannot be setting.

4.5.7 Multiplayer setting

In the page of **【Multiplayer setting】** , you can determine the maximum bonus game allowed and the timing to join a certain game.

1. Enter **【Operator settings】** → **【Game settings】** → **【Multiplayer setting】** , and the screen will display as below :



2. Use the **【Gear up】** and **【Gear down】** functions on the gear stick to choose the item, then press the **【Start】** button to start the process.
3. When the settings is completed, move the cursor to **【Exit】** , and press the **【Start】** button to return to **【Game settings】**

Note 1: When **【Bonus game for champion】** is set to be **【Off】** , then the maximum bonus game cannot be set.

Note 2: When **【Challenge in game player】** is set to be **【On】** , then players can challenge other ingame players; if it's set to be **【Off】** , then players can only challenge other players during the process.

Note Warning: To avoid errors, make sure the value of all cabinets are the game.

4.5.8 Volume setting

In the page of **Volume setting** , you can determine the start time of daytime and evenings and the corresponding volume.

1. Enter **Operator settings** → **Game settings** → **Volume setting** , and the screen will display as follow:

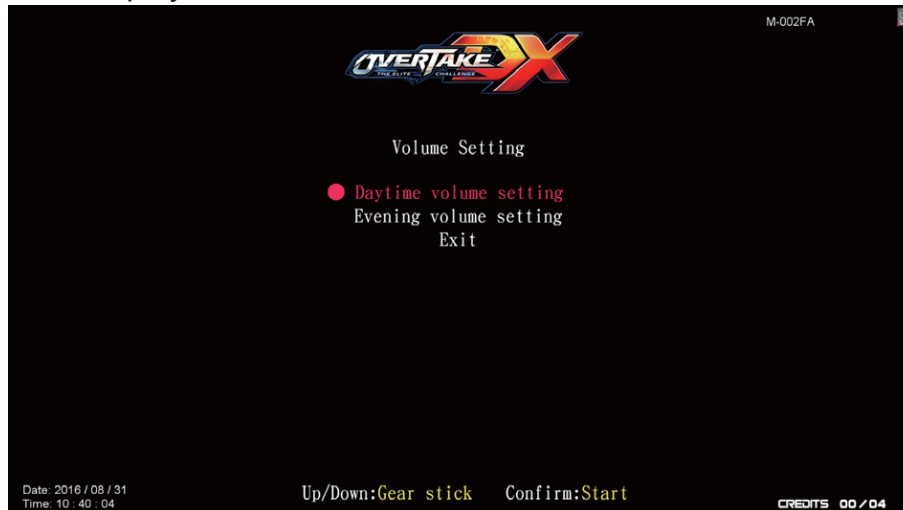

2. Use the **Gear up** and **Gear down** functions on the gear stick to choose the item.
3. Then press the **Start** button to enter the page of **Daytime volume setting** or **Evening volume setting** , and the screen will display as below:

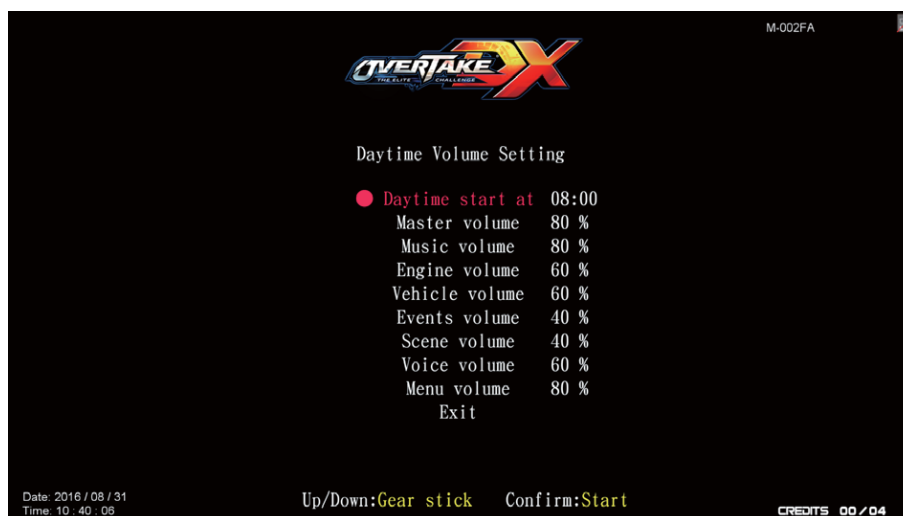

4. Use the **Gear up** and **Gear down** functions on the gear stick to choose the item, then press the **Start** button to start the process.
5. When the setting is completed, move the cursor to **Exit** to leave this page.
6. In the page of **Volume setting** , move the cursor to **Exit** , and press the **Start** button to return to **Game settings**

4.5.9 Flow time setting

In the page of **【Flow time setting】** , you can determine the duration of each process.

1. Enter **【Operator settings】** → **【Game settings】** → **【Flow time setting】** and the screen will display as below:

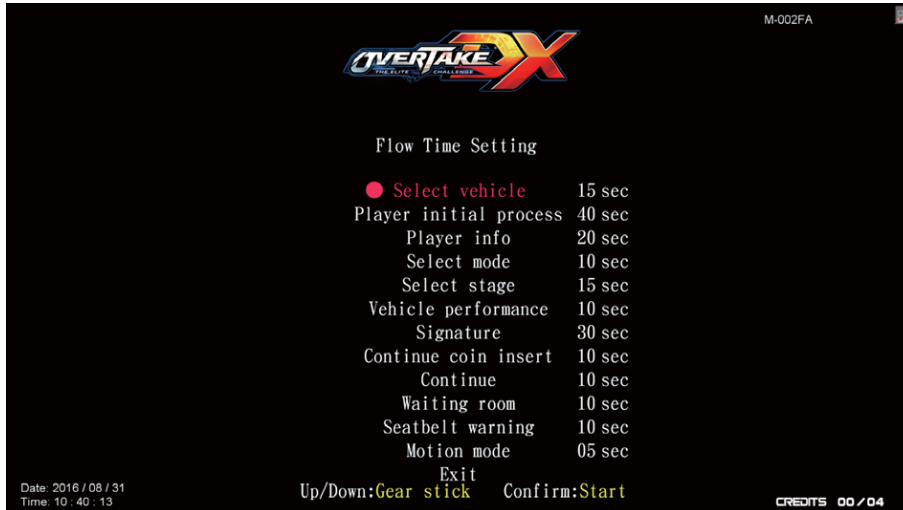

2. Use the **【Gear up】** and **【Gear down】** functions on the gear stick to choose the item, then press the **【Start】** button to start the process.
3. When the setting is completed, move the cursor to **【Exit】** , and press the **【Start】** button to return to **【Game settings】** .

Warning To avoid errors, make sure the difficult setting of all cabinets are the game.

4.5.10 Ranking board reset

In the page of **【Ranking board reset】** , you can reset all data on the ranking list.

1. Enter **【Operator settings】** → **【Game settings】** → **【Ranking board reset】** , and the screen will display as below:

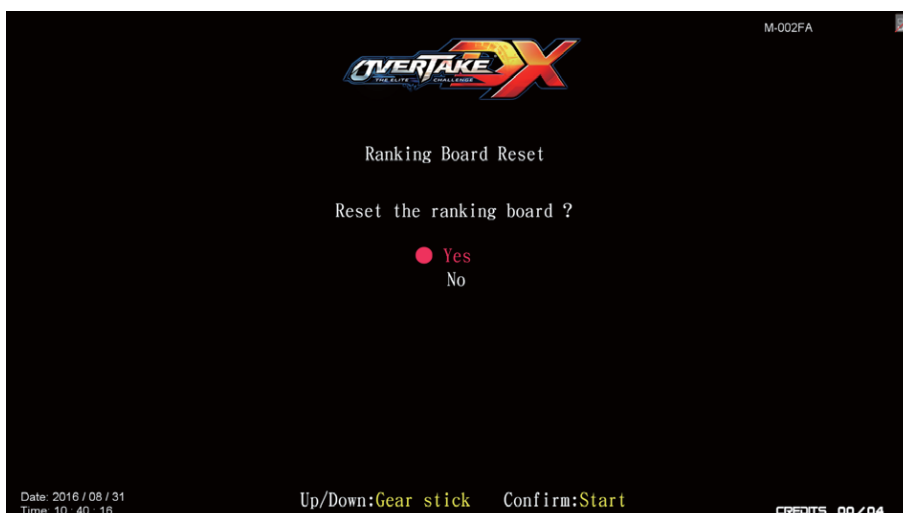

2. Use the **【Gear up】** and **【Gear down】** functions on the gear stick to choose **【Yes】** or **【No】** .
3. If **【Yes】** is selected, press the **【Start】** button to start resetting.
4. When the resetting process is completed, an icon of **【Reset completed】** will pop up, then press the **【Start】** button to return to **【Game settings】** .
5. If **【No】** is selected, then the screen will immediately return to **【Game settings】** .

4.5.11 Air spring adjustment

In the page of **【Air Spring Adjustment】** , you can adjust the air spring when the motion platform not in function right or malfunction.

1. Enter **【Operator setting】** → **【Game setting】** → **【Air spring adjustment】** , the screen will display as below :

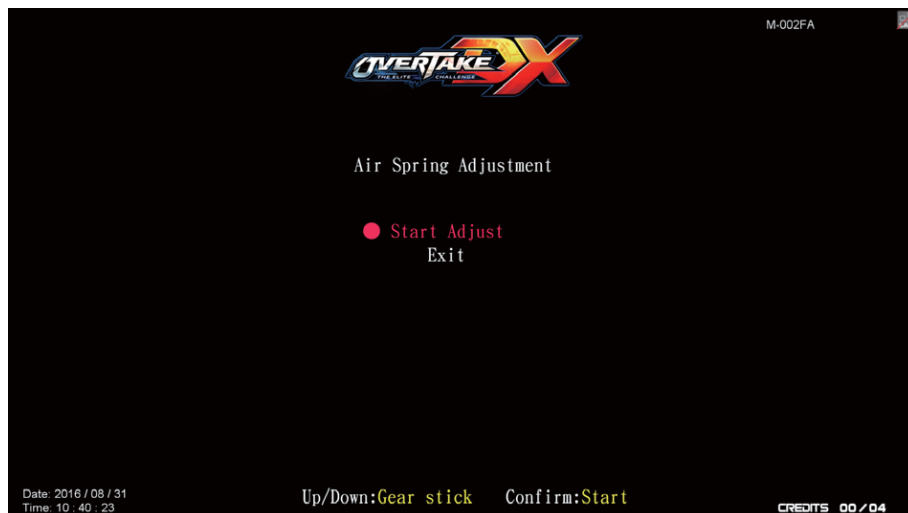

2. Use **【Gear up】** and **【Gear down】** to move the cursor to the **【Start adjust】** and press **【Start】** button to start adjustment.
3. After the adjustment is completed, move the cursor to the **【Exit】** and then press **【Start】** button to return to the **【Game settings】** .

Warning The Motion platform will not be function right or malfunction if the adjustment is not complete.

Warning After processed the system reset, remember to process the air spring adjustment.

4.5.12 Motion default setting

In the page of **【Motion default setting】** , you can set the default setting for the motion platform or close the motion platform.

1. Enter **【Operator setting】** → **【Game setting】** → **【Motion default setting】** , the screen will display as below :

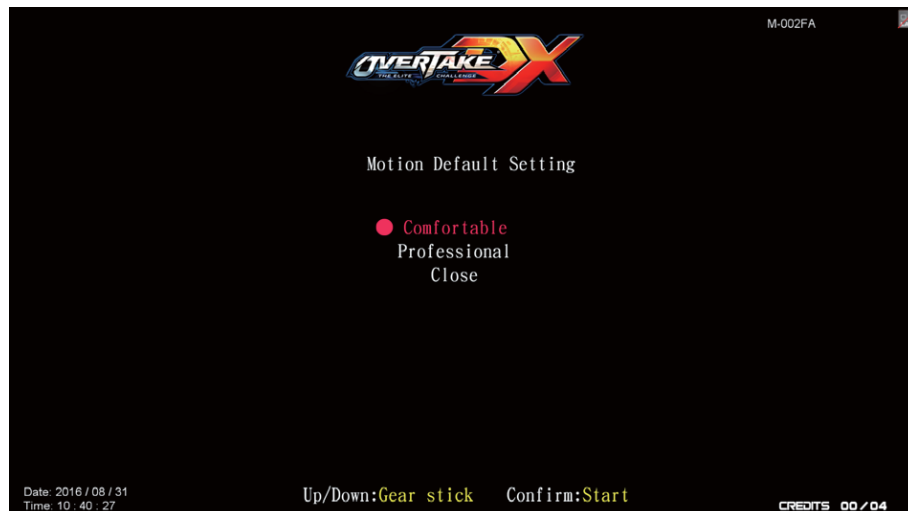

2. Use **【Gear up】** and **【Gear down】** to move the cursor to choose the default setting.
3. After your preferred default setting is chosen, press the **【Start】** button, and return to **【Game settings】** , then the default setting will be shown next to the **【Motion default setting】** .

4.5.13 Seat belts usage setting

In the page of **【Seat belts usage setting】** , you can set the seat belt **【On】** or **【off】** . When the setting is **【On】** , player must fasten seat belt to activates the motion platform during the game; When setting is **【Off】** , the motion platform will be actives without fasten the seat belt during the game.

1. Enter **【Operator settings】** → **【Game settings】** → **【Seat belts usage setting】** , the screen will display as below:

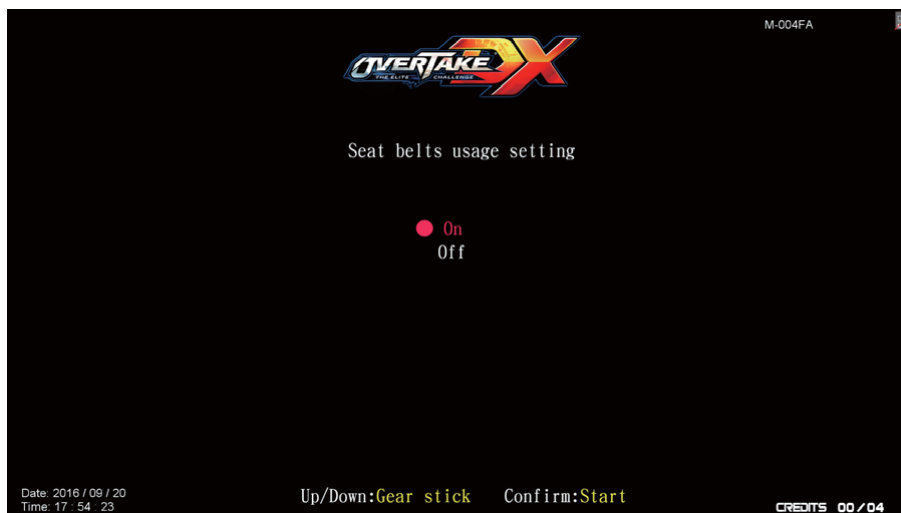

2. Use **【Gear up】** and **【Gear down】** to move the cursor to choose **【On】** or **【off】** .
3. After your preferred setting is chosen, press the **【Start】** button, and return to **【Game settings】** . Then the setting will be show next to the **【Seat belts usage setting】** .

Warning When the setting is **【Off】** , player doesn't need to fasten the seat belt during the game. For the player's own safety, the suggestion setting should be set to **【On】**

4.5.14 Game setting default volume

Name of the Setting	Default Setting	Available Setting
Difficult setting	Normal	Easy, Normal, Hard
Tunnel setting	Complex tunnel	Complex tunnel, Straight tunnel only
Coin setting > Freeplay	Off	Off, On
Coin setting > Currency setting	Coins	Coins, Tokens, Dollar, Peso, Pound, Swipe Card
Coin setting > Start game	04	01~20
Coin setting > Continue game	04	01~20
Multiplayer setting > Bonus game for champion	Off	Off, On
Multiplayer setting > Max bonus game	3	1~10, Infinite
Multiplayer setting > Challenge ingame player	Off	Off, On
Volume setting > Daytime volume > Daytime start at	08:00	00:00~24:00
Volume setting > Daytime volume > Master volume	80%	00%~100%
Volume setting > Daytime volume > Music volume	80%	00%~100%
Volume setting > Daytime volume > Engine volume	60%	00%~100%
Volume setting > Daytime volume > Vehicle volume	60%	00%~100%
Volume setting > Daytime volume > Events volume	40%	00%~100%
Volume setting > Daytime volume > Scene volume	40%	00%~100%
Volume setting > Daytime volume > Voice volume	60%	00%~100%
Volume setting > Daytime volume > Menu volume	80%	00%~100%
Volume setting > Evening volume > Daytime start at	20:00	00:00~24:00
Volume setting > Evening volume > Master volume	70%	00%~100%
Volume setting > Evening volume > Music volume	80%	00%~100%
Volume setting > Evening volume > Engine volume	60%	00%~100%
Volume setting > Evening volume > Vehicle volume	60%	00%~100%
Volume setting > Evening volume > Events volume	40%	00%~100%
Volume setting > Evening volume > Scene volume	40%	00%~100%
Volume setting > Evening volume > Voice volume	60%	00%~100%
Volume setting > Evening volume > Menu volume	80%	00%~100%
Flow time setting > Select vehicle	15 sec	05, 10, 15, 20, 25, 30
Flow time setting > Player initial process	40 sec	30, 35, 40, 45, 50, 55, 60
Flow time setting > Player info	20 sec	05, 10, 15, 20, 25, 30
Flow time setting > Select mode	10 sec	05, 10, 15, 20, 25, 30
Flow time setting > Select stage	15 sec	05, 10, 15, 20, 25, 30
Flow time setting > Vehicle performance	10 sec	05, 10, 15, 20, 25, 30
Flow time setting > Signature	30 sec	05, 10, 15, 20, 25,30, 35, 40, 45, 50, 55, 60
Flow time setting > Continue coin insert	10 sec	05, 10, 15, 20, 25, 30
Flow time setting > Continue	10 sec	05, 10, 15, 20, 25, 30
Flow time setting > Waiting room	10 sec	05, 10, 15, 20
Flow time setting > Seatbelt warning	10 sec	05, 10, 15, 20
Flow time setting > Motion mode	05 sec	05, 10, 15, 20
Motion default setting	Comfortable	Comfortable, Professional, close
Seat belts usage setting	On	Off, On

4.6 System settings

In the page of **【System settings】** , you can set up the system or set the system to the default setting.

1. Enter **【Operator settings】** → **【System settings】** , and the screen will display as below:

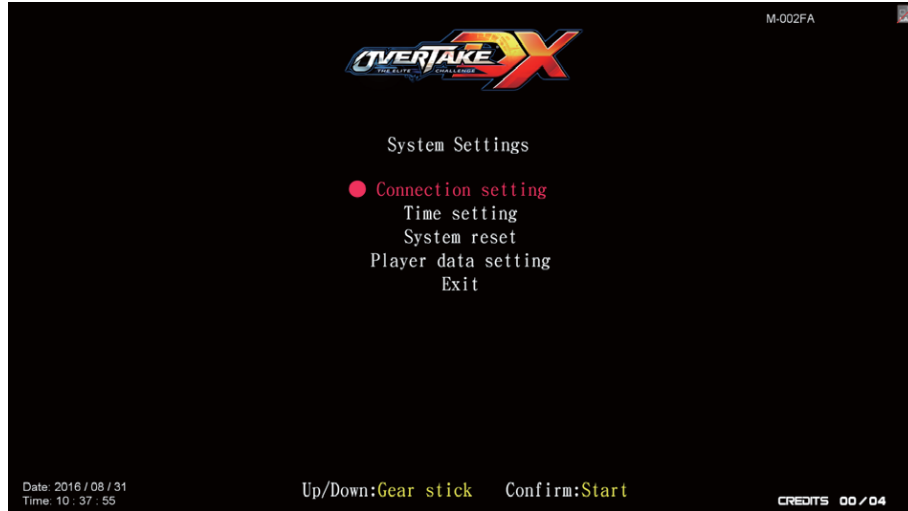

2. Use the **【Gear up】** and **【Gear down】** functions on the gear stick to choose the item, and the item chosen will appear in red.
3. Press the **【Start】** button to confirm or enter the sub menu.
4. When the setting is completed, move the cursor to **【Exit】** , and press the **【Start】** button to return to **【Operator settings】** .
5. Regarding the detailed descriptions of the sub menu in **【System setting】** , refer to the following content.

4.6.1 Connection setting

In the page of **【System settings】** , you can set up the system or set the system to the default setting.

1. Enter **【Operator settings】** → **【System settings】** → **【Connection settings】** , and the screen will display as below:

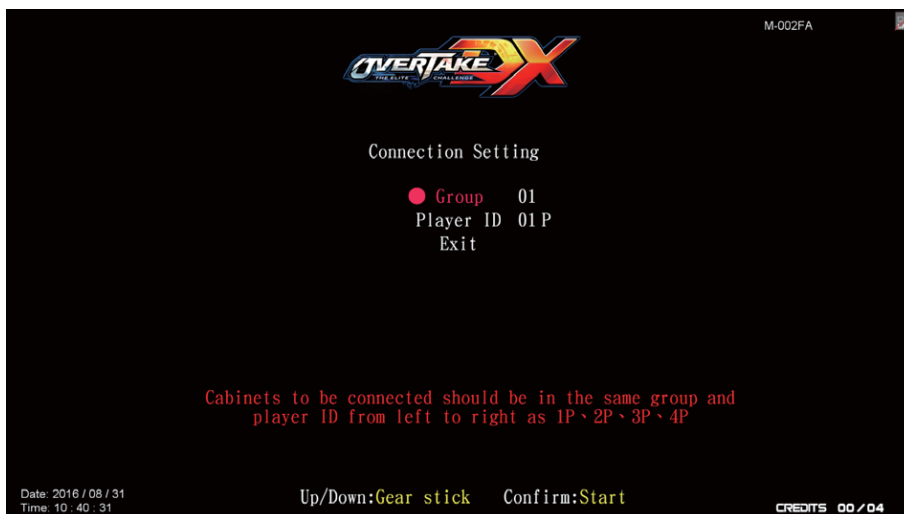

2. Use the **【Gear up】** and **【Gear down】** functions on the gear stick to choose the item to set up, and press the **【Start】** button.
3. When the setting process is completed, move the cursor to **【Exit】** , and press the **【Start】** button to return to **【System setting】** .

Warning Those cabinets to be connected should be set to the same group m and player ID as 1P, 2P, 3P, and 4P (From left to right) .

4.6.2 Time setting

In the page of **【Time setting】** , you can set up your local time.

1. Enter **【Operator settings】** → **【System settings】** → **【Time setting】** , and the screen will display as below :

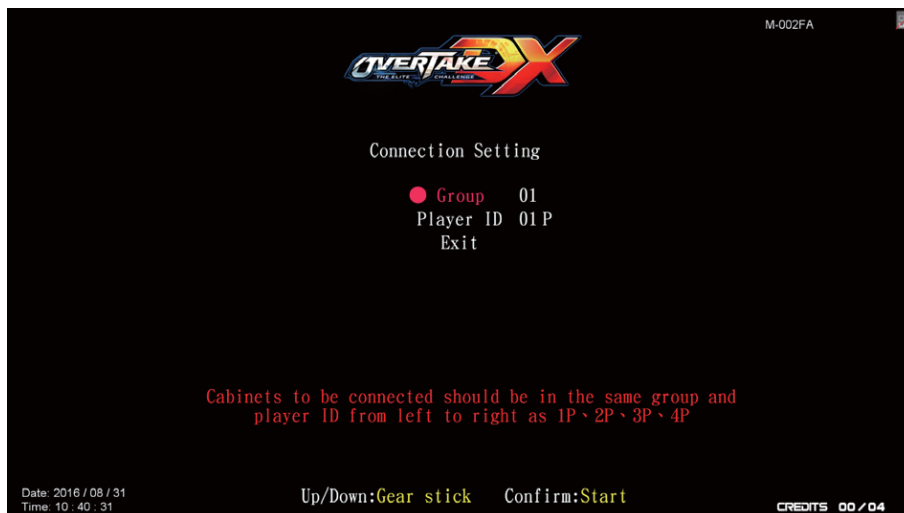

2. Use the **【Gear up】** and **【Gear down】** functions on the gear stick to choose the item to set up, and press the **【Start】** button.
3. When the setting process is completed, move the cursor to **【Exit】** , and press the **【Start】** button to return to **【System setting】** .

Note Those cabinets to be connected should be set to the same group m and player ID as 1P, 2P, 3P, and 4P (From left to right) .

4.6.3 System reset

In the page of **【System reset】** , you can reset the system data to the default setting.

1. Enter **【Operator settings】** → **【System settings】** → **【System reset】** , and the screen will display as below :

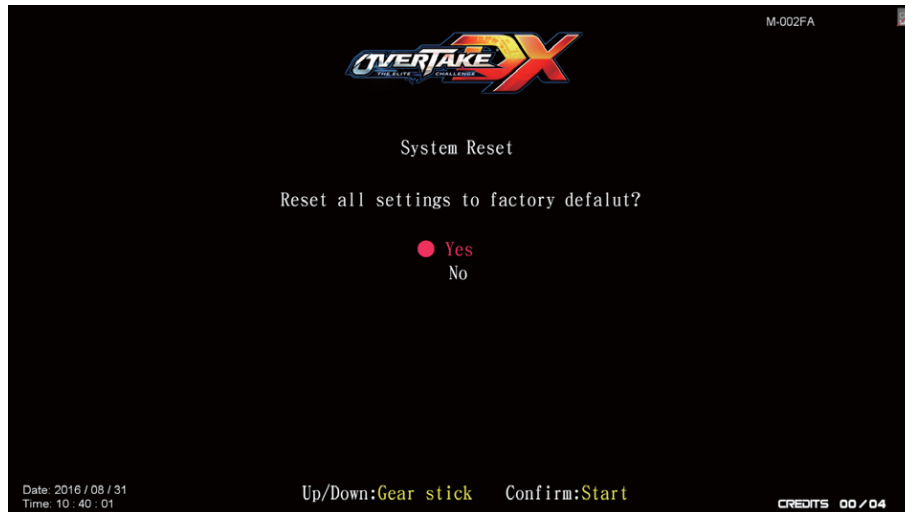

2. Use the **【Gear up】** and **【Gear down】** functions on the gear stick to choose **【Yes】** or **【No】** .
3. When **【Yes】** is chosen, press the **【Start】** button to start the resetting process,
4. After the resetting process, an icon of **【Completed】** will pop up, then press the **【Start】** button to return to **【System setup】** .
5. When **【No】** is chosen, then the screen will automatically direct to the page of **【System setting】** .

Note

Those cabinets to be connected should be set to the same group m and player ID as 1P, 2P, 3P, and 4P (From left to right) .

4.6.4 Player data setting

In the page of **【Player data setting】** , you can set the player data automatic delete time or delete player data manually.

1. Enter **【Operator setting】** → **【System setting】** → **【Player data setting】** , and the screen will display as below :

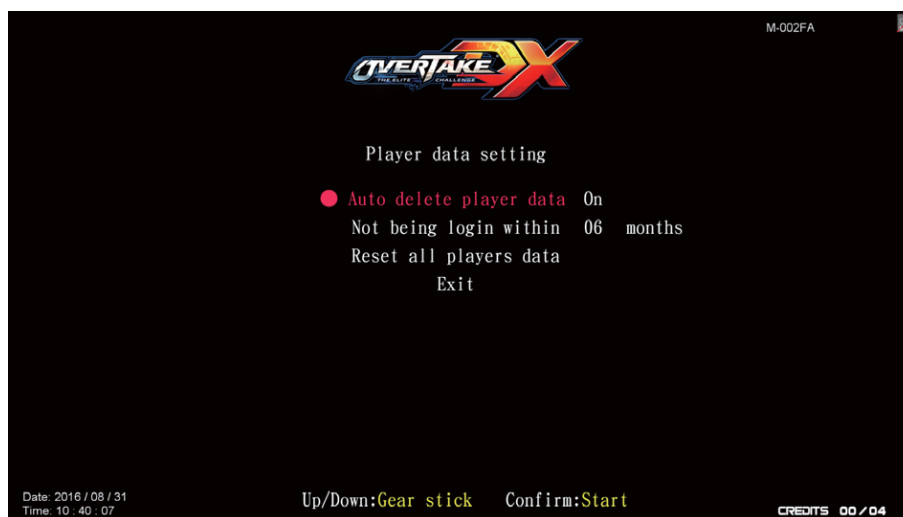

2. Use the **【Gear up】** and **【Gear down】** functions on the gear stick to choose the item to set up, and press the **【Start】** button.
3. When the set up is completed, move the cursor to **【Exit】** and press the **【Start】** button to return to **【System setting】** .

Warning All the machines must reset player data at same time, or reset will be failure.

Warning When player data has been reset, the data cannot be restored.

- Default setting

Name of the Setting	Default setting	Available Setting
Auto delete player data	On	On, Off
Not being login within	06	01~12

4.7 Income data

In the page of **Income data** , you can check the daily, monthly and total revenue.

1. Enter **Operator settings** → **Income data** , and the screen will display as below:

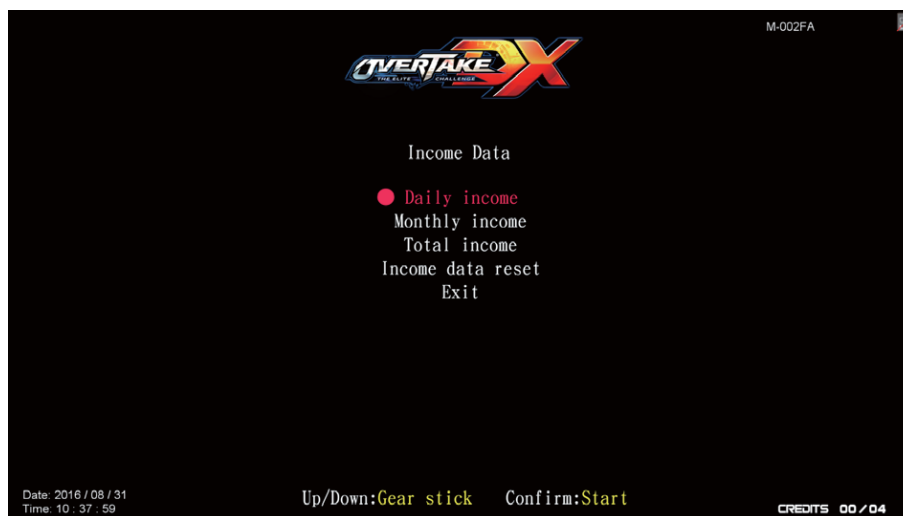

2. Use the **Gear up** and **Gear down** functions on the gear stick to move the cursor, and the item selected will appear in red.
3. Press the **Start** button to confirm or enter the sub menu.
4. Move the cursor to **Exit** and press the **Start** button to return to the **Operator settings** .
5. Regarding the detailed data of the sub menu in the **Income data** , refer to the following content.

4.7.1 Daily income

In the page of **【Daily income】** , you can check the daily revenue of each cabinet.

1. Enter **【Operator settings】** → **【Income data】** → **【Daily income】** , and the screen will display as below :

Date	Coin(s)	Total game	New game	Continue	Freeplay	Bonus	Versus	Service	Current coin(s)	Current service	Total time	Game time	Avg. game time
2016/8/31	0	0	0	0	0	0	0	0	0	0	0:0:2	0:0:0	0:0:0

Date: 2016 / 08 / 31
 Time: 10 : 40 : 13
 Previous/Next: Gear stick Exit: Start
 CREDITS 00 / 04

Descriptions of each items:

Item	Descriptions
Data	Date of data
Coin(s)	The total number of coins inserted that day
Total game	The total number of games played that day
New game	The total number of new games that day
Continue	The total number of games continued that day
Freeplay	The total number of freeplay that day
Bonus	The total number of bonus game that day
Versus	The total number of versus game that day
Service	The total number of service use that day
Current coin(s)	That actual number of coins counted that day
Current service	The actual use of service button that day
Total time	The entire duration of time when the cabinet is turned on that day
Game time	The entire duration of time when games are played that day
Avg. game time	The average play time of the day Formula : Game time ÷ Total game

2. Use the **【Gear up】** and **【Gear down】** functions on the gear stick to move the page, and press the **【Start】** button to return to **【Income data】** .

4.7.2 Monthly income

In the page of **【Monthly income】** , you can check the daily revenue of each cabinet.

1. Enter **【Operator settings】** → **【Income data】** → **【Monthly income】** , and the screen will display as below :

Date	Coin(s)	Total game	New game	Continue	Freyplay	Bonus	Versus	Service	Current coin(s)	Current service	Total time	Game time	Avg. game time
2016/8	0	0	0	0	0	0	0	0	0	0	0:0:2	0:0:0	0:0:0

Previous/Next: Gear stick Exit: Start

Descriptions of each items:

Item	Descriptions
Data	Date of data
Coin(s)	The total number of coins inserted that month
Total game	The total number of games played that month
New game	The total number of new games that month
Continue	The total number of games continued that month
Freyplay	The total number of freeplay that month
Bonus	The total number of bonus game that month
Versus	The total number of versus game that month
Service	The total number of service use that month
Current coin(s)	That actual number of coins counted that month
Current service	The actual use of service button that month
Total time	The entire duration of time when the cabinet is turned on that month
Game time	The entire duration of time when games are played that month
Avg. game time	The average play time of the month Formula : $\text{Game time} \div \text{Total game}$

4.7.3 Total income

In the page of **【Monthly income】** , you can check the daily revenue of each cabinet.

1. Enter **【Operator settings】** → **【Income data】** → **【Monthly income】** , and the screen will display as below :

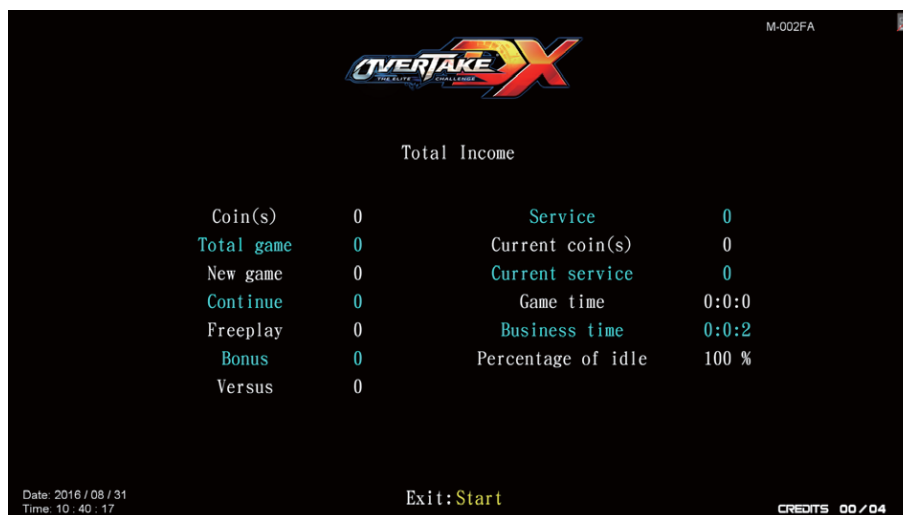

Total Income			
Coin(s)	0	Service	0
Total game	0	Current coin(s)	0
New game	0	Current service	0
Continue	0	Game time	0:0:0
Freeplay	0	Business time	0:0:2
Bonus	0	Percentage of idle	100 %
Versus	0		

Date: 2016 / 08 / 31
Time: 10 : 40 : 17
Exit: Start
CREDITS 00 / 04

Descriptions of each items:

Item	Descriptions
Coin(s)	The total number of coins inserted
Total game	The total number of games played
New game	The total number of new game created
Continue	The total number of games continued
Freeplay	The total number of free game played
Bonus	The total number of bonus game played
Versus	The total number of versus game played
Service	The total use times of the service button
Current coin(s)	The actual number of coin counted
Current service	The actual use of service button
Game time	The entire duration of play time
Business time	The entire duration of time when the cabinets is turn on
Percentage of idle	The amount of idle time among the entire period when the cabinet is turned on Formula : (Idle time ÷ Business time) × 100%

4.7.4 Income data reset

In the page of **Income data reset** , you can delete the data of daily income and monthly income.

1. Enter **Operator settings** → **Income data** → **Income data reset** , and the screen will display as below:

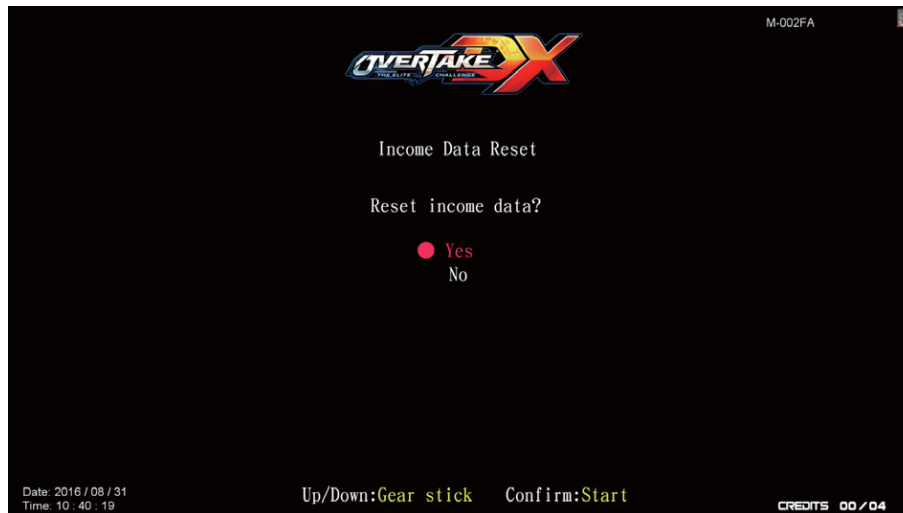

2. Use the **Gear up** and **Gear down** function on the gear stick to choose between **Yes** and **No** .
3. When **Yes** is selected, press the **Start** button to reset the data.
4. When done, an icon of **Completed** will pop up, then press the **Start** button to return to **Income data** .
5. When **No** is selected, then the screen will automatically direct to the page of **Income data**

Note This function cannot delete the data of **Total income** .

4.8 Troubleshooting

Problem	Easy troubleshooting
The throttle, brake or the steering wheel fail to work.	Enter 【Operator settings】 → 【Hardware test】 → 【I/O test】 to run the testing. If testing results are shown, enter 【Operator settings】 → 【Game settings】 → 【I/O adjustment】 to adjusting I/O. If no testing results are shown, contact your local distributor to replace the corresponding VR.
One of the speakers does not produce sound.	Check if the plugs between speakers and power amplifier are coming off. If this problem persists, contact your local distributor to replace parts.
The light of the LED plate is not on.	Check if the plugs between speakers and power amplifier are coming off. If this problem persists, contact your local distributor to replace parts.
The buttons do not respond.	Enter 【Operator settings】 → 【Hardware test】 → 【I/O test】 to run the testing. If lights do not respond, refer to 【Replacing parts】 and disassemble the cap to check if plugs are coming off. disassemble the cap to check if plugs are coming off. If this problem persists, contact your local distributor to replace the corresponding VR.
The shift gear does not respond.	Enter 【Operator settings】 → 【Hardware test】 → 【I/O test】 to run the testing. If this problem persists, contact your local distributor to replace the shift gear.
The screen appears blank after the power is on.	Check if the plugs between the cabinet and screen are well connected, and whether DVI connectors on both sides are coming off. Check if the cabinet is plugged into the port of the video card. If this problem persists, contact your local distributor.
The speakers do not produce sound.	Open the door of the cash box, and check if the master volume is adjusted to its minimum value. Open the maintenance door located in the bottom of the cabinet, and check if the volume of the power a mplifier is . adjusted to its minimum value. Check if the power of the power amplifier is turned on. Check if the plugs between the power amplifier and cabinet are coming off.
Local internet not connected	Open the rear maintenance door of cabinet, check the network cable is properly connected to the E3100, and the router(HUB) . Enter 【Operator settings】 → 【System settings】 → 【Connection setting】 assign the cabinets into the same group but different player ID.
The motion platform not function	Make sure the 【Emergency stop】 button is off. If it's on, press the 【Emergency stop】 button to turn it off. Enter 【Operator settings】 → 【Game settings】 → 【Air spring adjustment】 Enter 【Operator settings】 → 【Hardware test】 → 【Air spring test】 to run the testing. If this problem persists, contact your local distributor.

※If any of the above mentioned problems is unsolvable, contact your local distributor.

5. Maintenance and Service

5.1 Maintenance and service

Even though the machine works normally for a long time, the fault will occur. Therefore, please perform routine check and maintenance concerning the following to ensure a long-term use.

■ External Inspection

- Stick “Warning” stickers correctly, keep it legible.
- Firmly tighten the bolt for each adjuster.
- Tighten screws for speaker assembly.
- Tighten the signboard firmly.
- Check if the screws fixing the parts loose.
- Check if the connectors loose or missing.

■ Operation Inspection (With power on)

- Sound is normally emitted from the speakers or not.
- Fluorescent lamps and LED and button lamps light up or not
- Coin acceptor works properly or not.
- Lifting and falling devices work properly or not.
- YZ sensor works properly or not.

After completing all the checks, operate the game again and check the above items with full care!

■ Servicing (conducted by a technician only)

- Cut off the main power supply to avoid injury or electric shock when performing maintenance.
- Please contact our service center when performing any work that is not specified in this Manual, and follow the instruction provided by the service center.
- For consumables and spare parts (including screws), please use products specified by Wahlap Technology.
- Even though the main power is cut off, there is still high temperature and high pressure in the power board and the monitor. The person will be burnt or get an electric shock if he touches such parts. Please pay full attention to avoid contact.
- Be sure to cut off the main power when you alter a spare part or unplug a connector.

5.2 Part Replacement

5.2.1 Maintenance of exhaust pipe and light board

1. Remove the four screws of seat exhaust pipe assembly. Remove the exhaust pipe assembly.

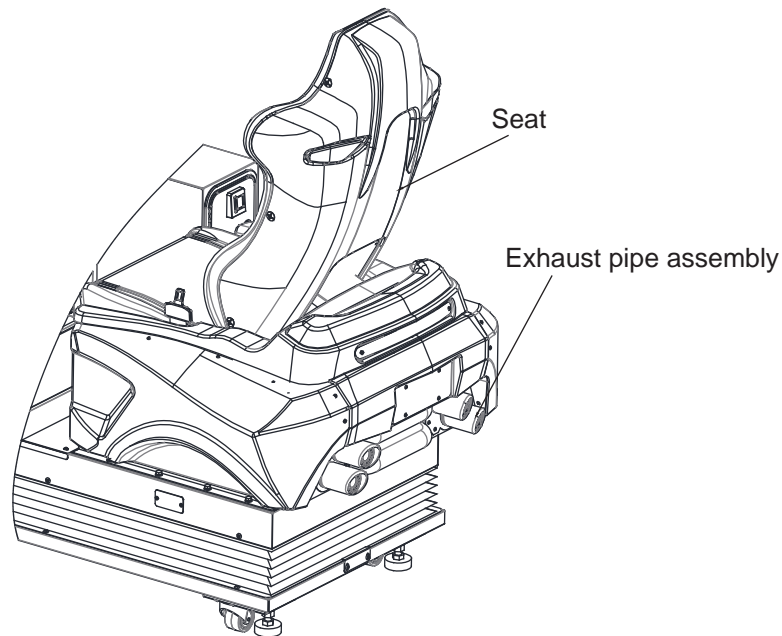

2. Remove the four screws fixing the exhaust pipe and the light board.

3. Remove the four screws fixing LED board. Replace the LED board.

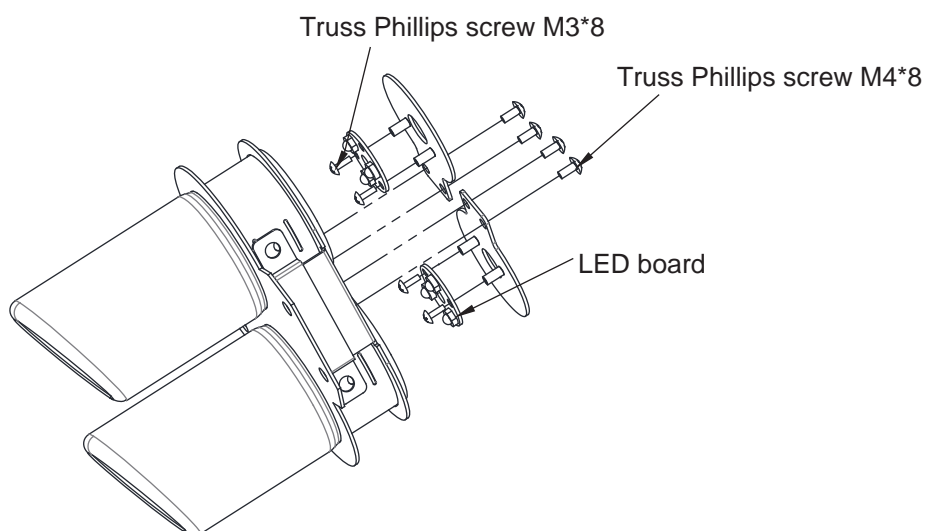

4. After replacement, assemble in reverse order.

5.2.2 Maintenance of the instrument panel LED

1. Remove the seven screws of the rear cover of console. Remove the rear cover of console.

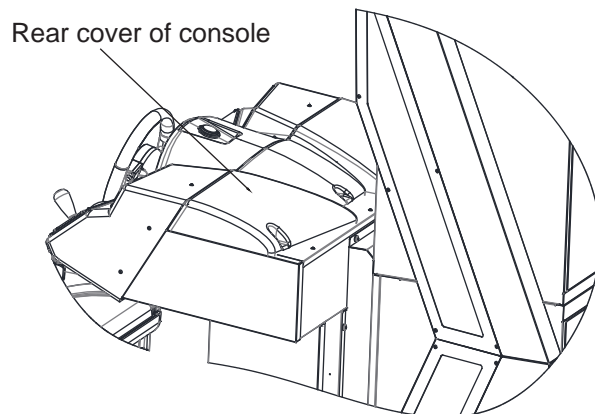

2. Remove the two screws fixing the steering wheel light board assembly. Remove the steering wheel light board assembly.

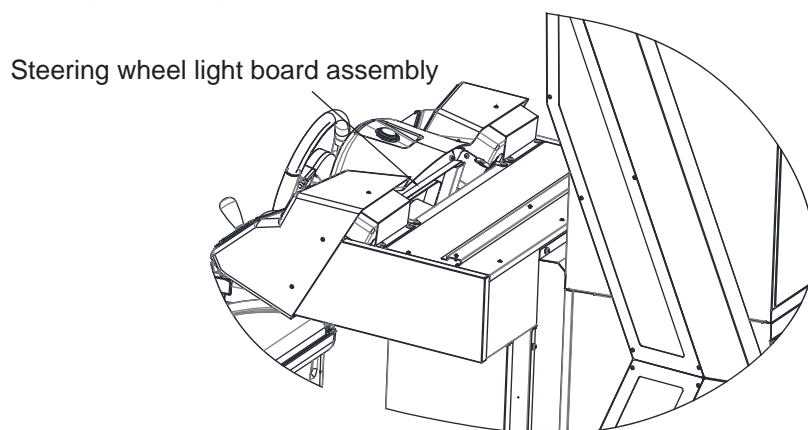

3. Remove the four screws fixing the LED board. Replace the LED board.

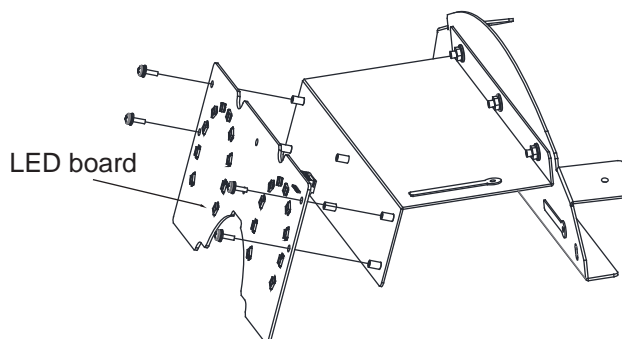

4. After replacement, assemble in reverse order.

5.2.3 Maintenance of the instrument panel LED

- 1.Remove the four screws of the Decorative board. Remove the Decorative board.
- 2.Remove the seven screws fixing light box acrylic. Remove the light box acrylic and replace the acrylic light bar.
- 3.After replacement, assemble in reverse order.

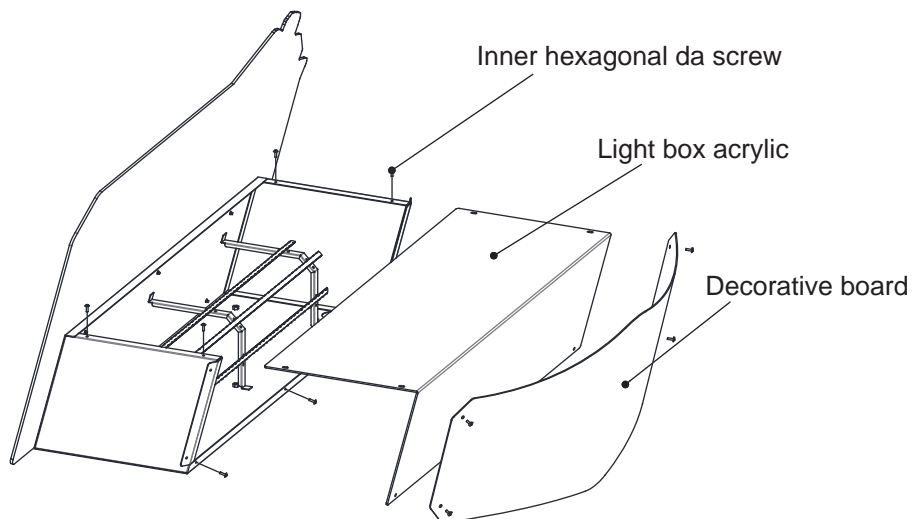

5.2.4 Maintenance of front light board

- 1.Remove the three screws on the rear door of the back screen access door.
Remove the back screen access door.
- 2.Remove the four screws fixing the front light board assembly. Replace the LED board.
- 3.After replacement, assemble in reverse order.

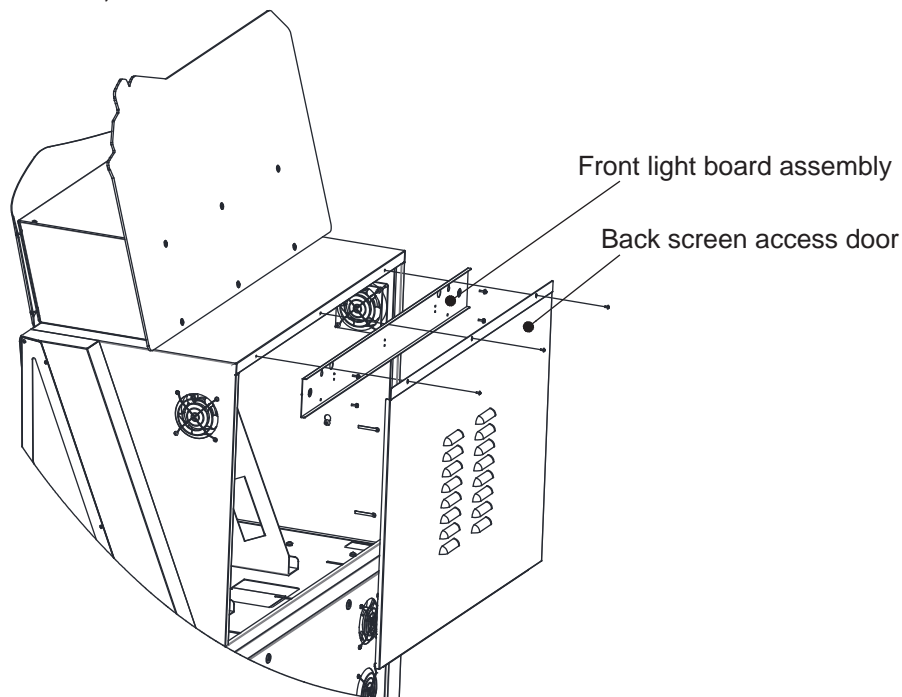

5.2.5 Maintenance of LCD

1. Remove the three screws on the rear door of the back screen access door. Remove the back screen access door.
2. Remove the four screws fixing the LCD assembly. Replace the LCD assembly.
3. After replacement, assemble in reverse order.

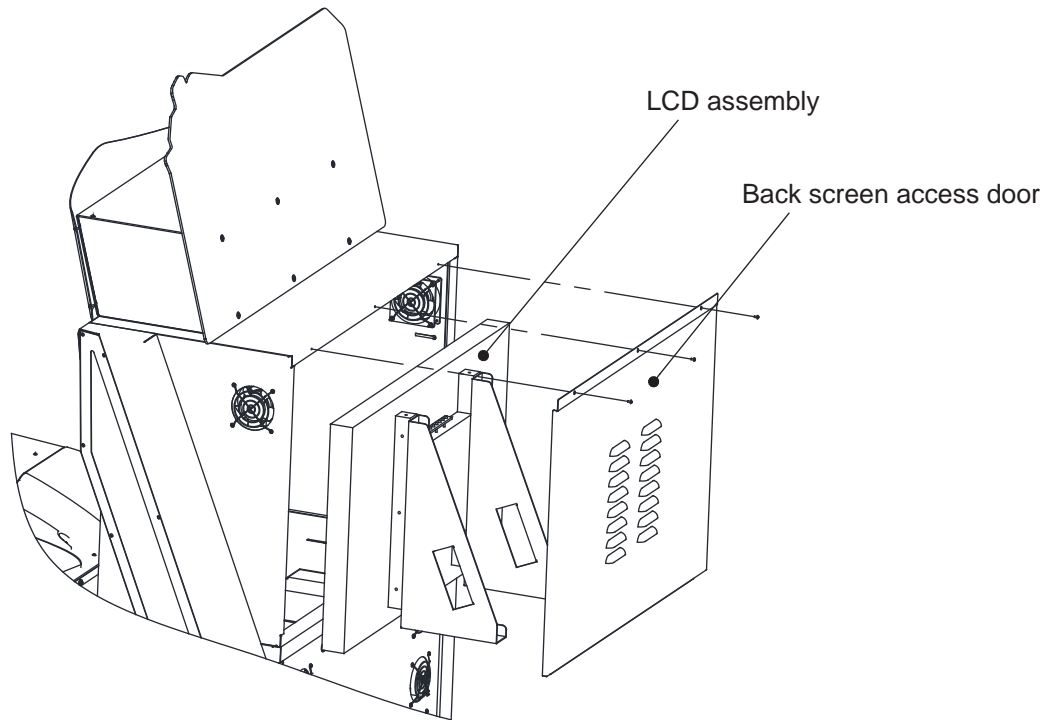

5.2.6 Maintenance of seat lamp

- 1.Remove the 24 screws of the seat side cover assembly. Remove the seat side cover assembly.
- 2.Remove the screws fixing the light bar holder. Remove the light bar for replacement.
- 3.After replacement, assemble in reverse order.

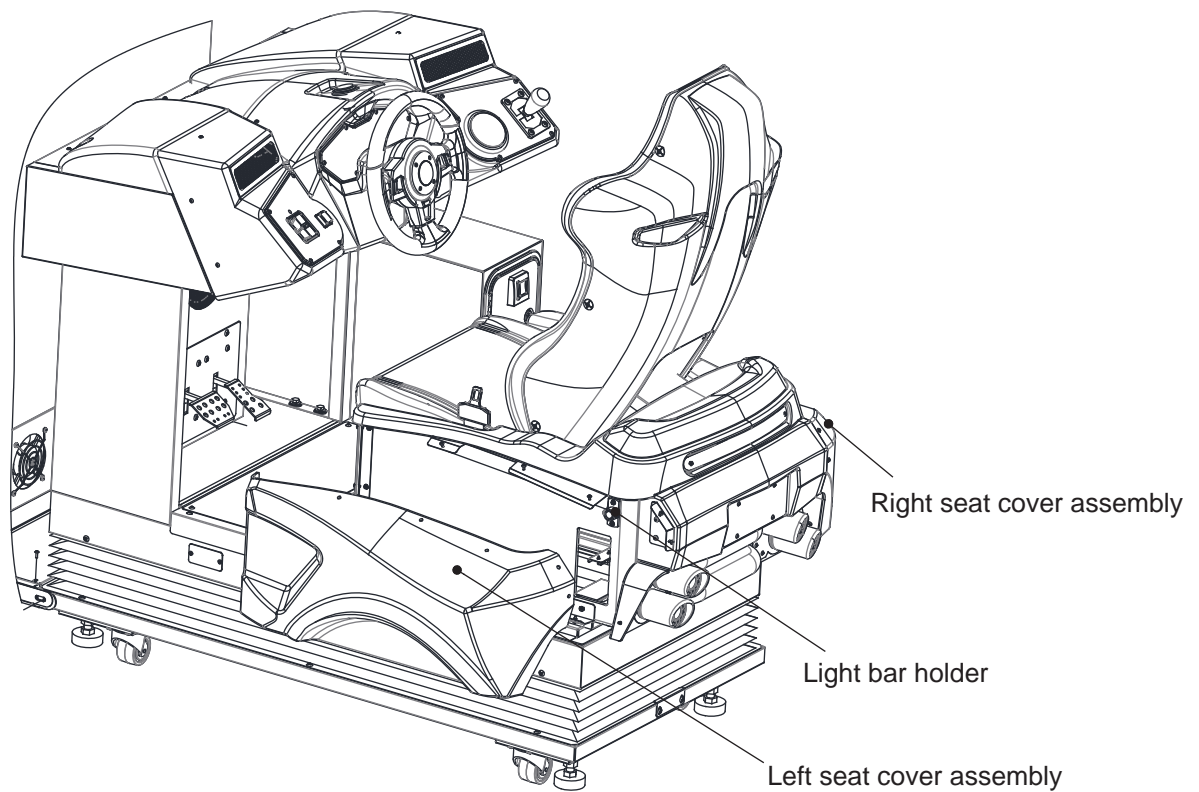

5.2.7 Maintenance of host

1. Remove the two wing screws of the host assembly. Remove the host assembly and replace.
2. After replacement, assemble in reverse order.

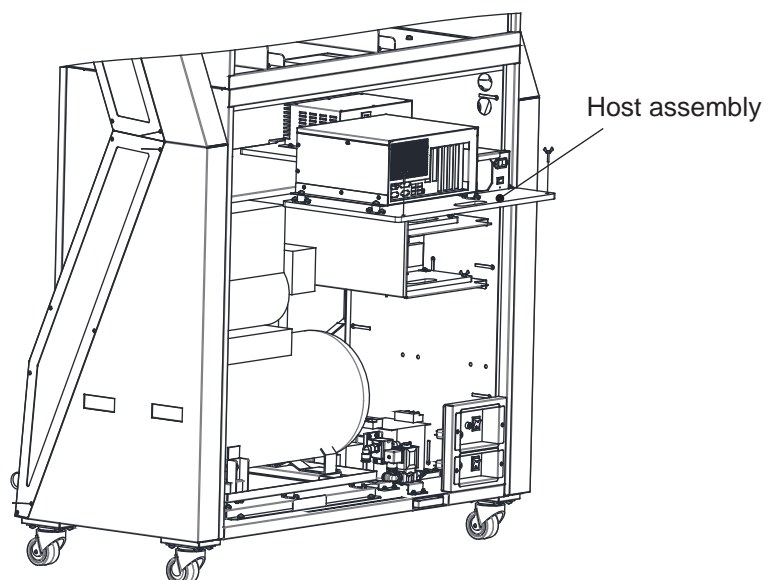

5.2.8 Maintenance of air compressor

1. Remove the four screws fixing the air compressor assembly. Remove the air compressor.
2. After replacement, assemble in reverse order.

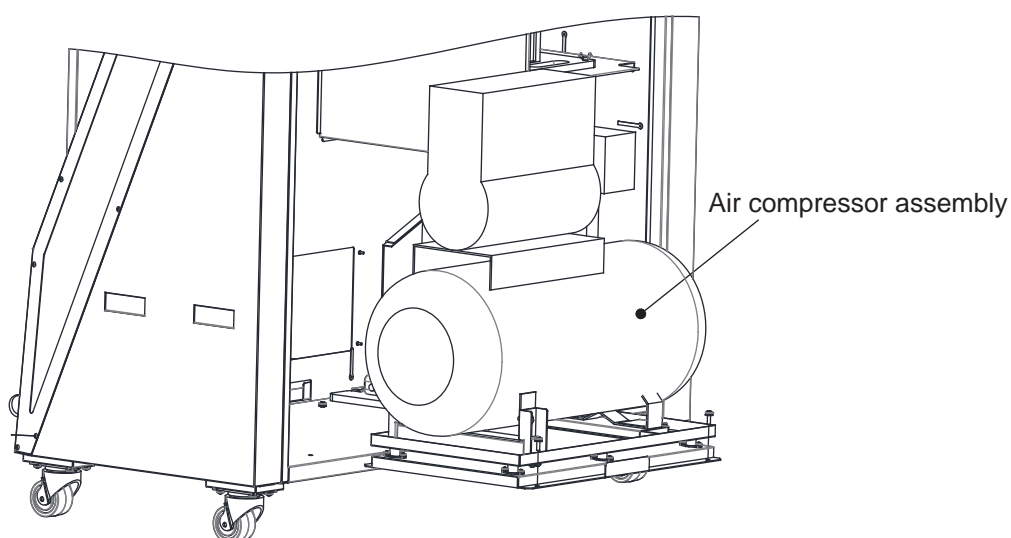

5.2.9 Maintenance of fluid control valve

1. Remove the two nuts fixing the fluid control valve. Remove the fluid control valve and replace.
2. After replacement, assemble in reverse order.

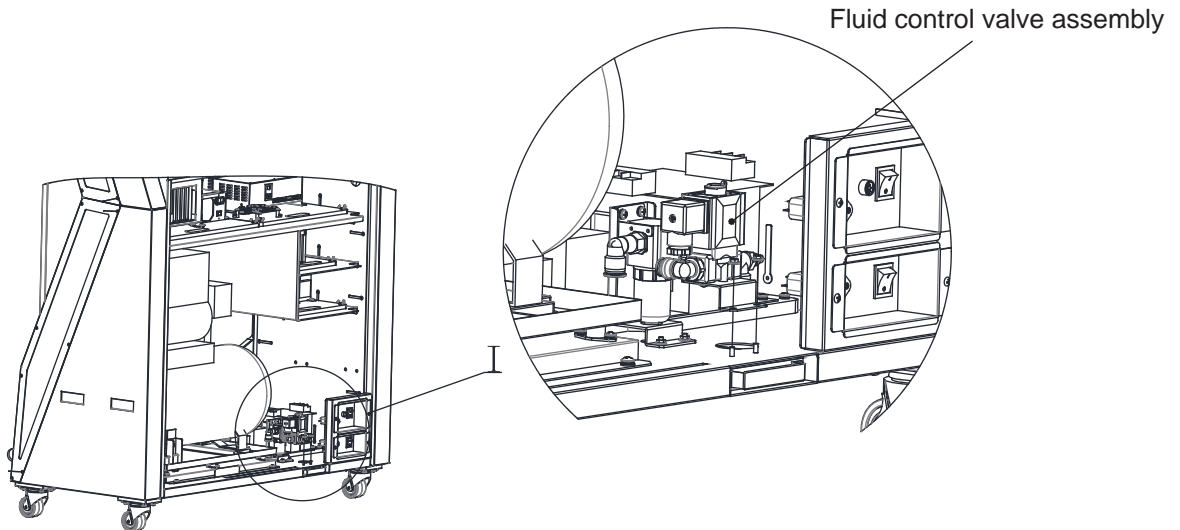

5.2.10 Maintenance of filter

1. Remove the two screws fixing the filter assembly. Replace the filter.
2. After replacement, assemble in reverse order.

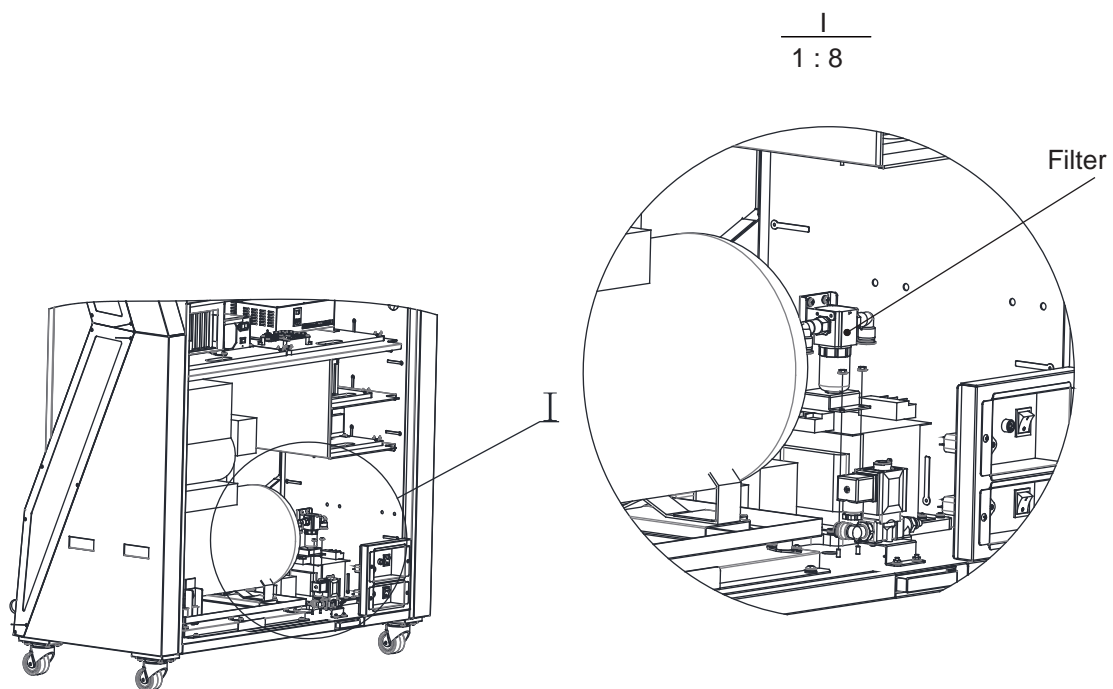

5.2.11 Maintenance of air compressor control board and solenoid valve

- 1.Remove the four screws fixing the pedal. Remove the pedal and replace the solenoid valve.
- 2.Remove the two screws fixing the waterproof cover. Remove the air compressor control board.
- 3.After replacement, assemble in reverse order.

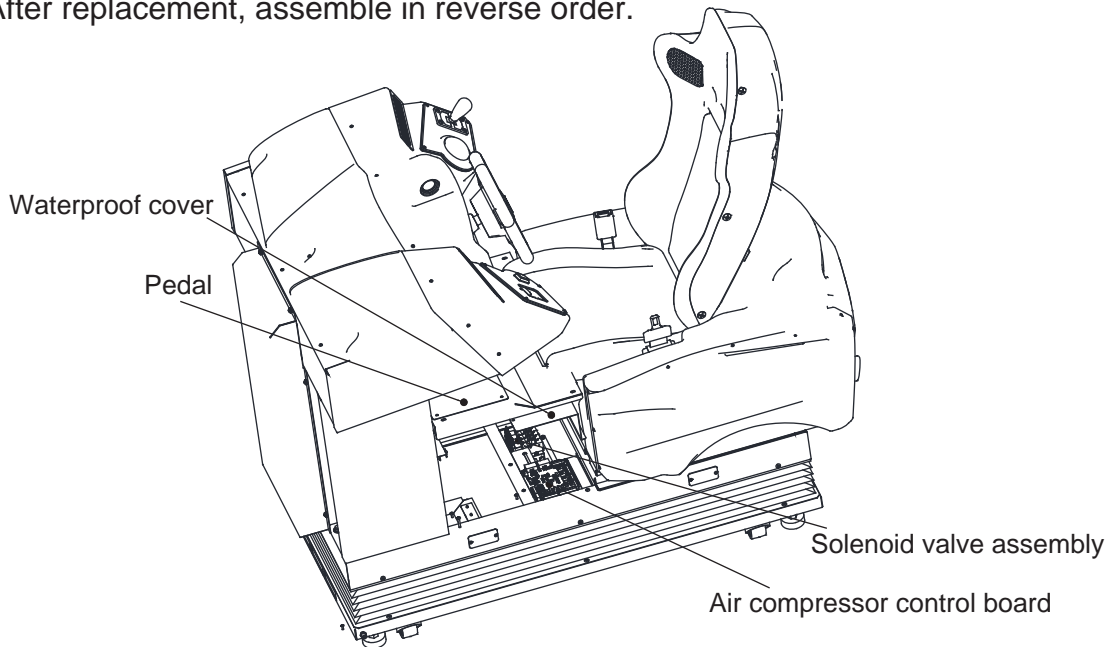

5.2.12 Maintenance of motor control board and I/O board

- 1.Remove the eleven screws fixing the back console cover and the cover plate. Remove the back console cover and the cover plate.
- 2.Remove the eight screws fixing the motor control board and I/O board for replacement.
- 3.After replacement, assemble in reverse order.

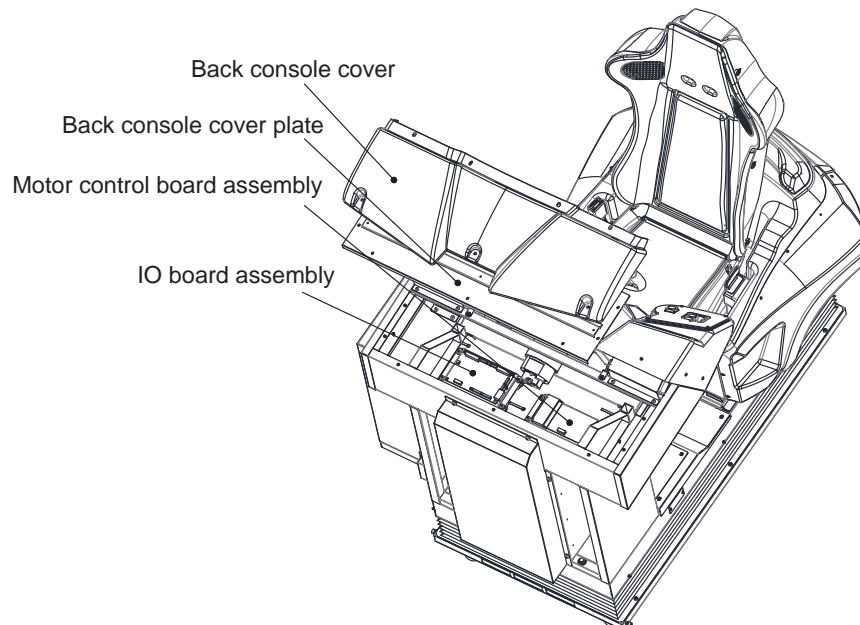

5.2.13 Maintenance of motion sensor

1. Remove the two screws fixing the sensor assembly. Remove the sensor assembly.

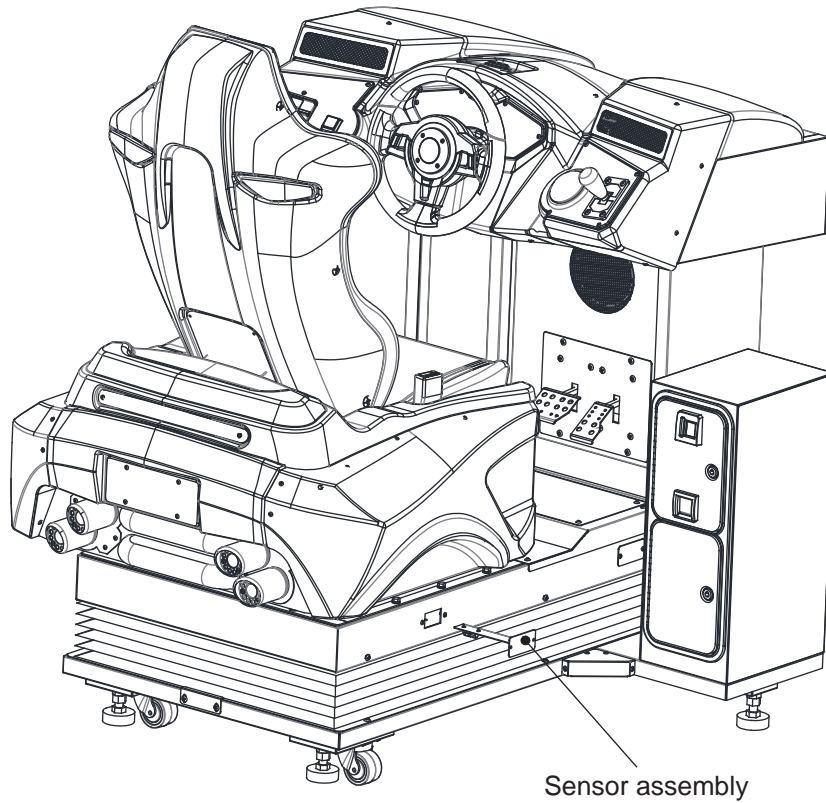

2. Remove the two screws fixing the sensor. Remove the sensor.

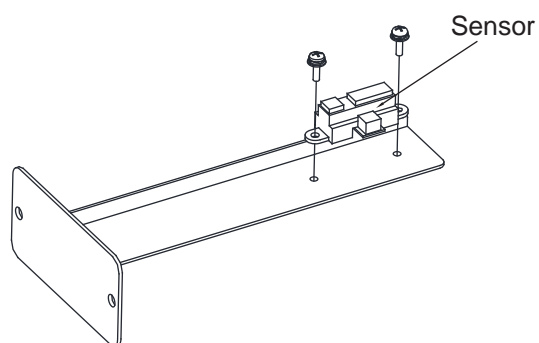

3. After replacement, assemble in reverse order.

5.2.14 Maintenance of screen light guide

1. Remove the seven screws fixing the screen light guide assembly. Remove the screen light guide assembly.

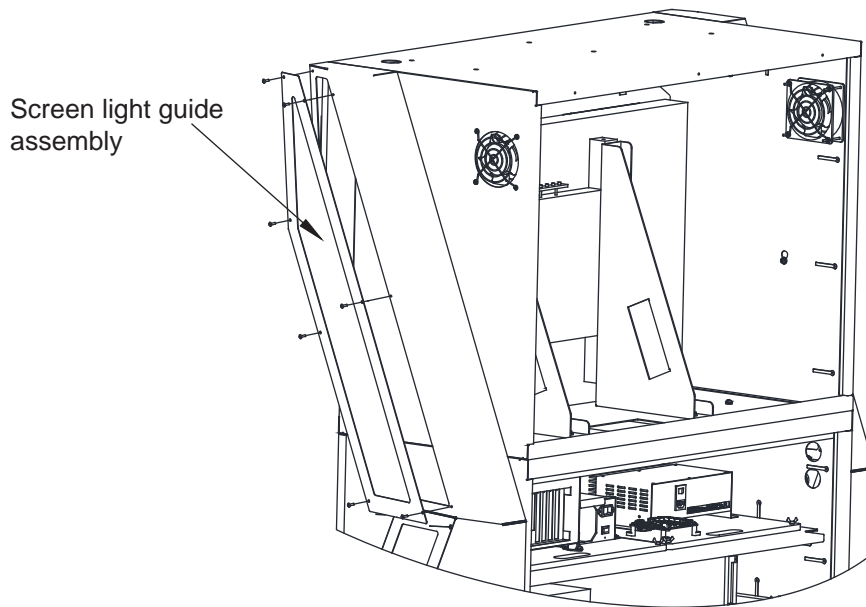

2. Remove the six nuts fixing the screen light guide acrylic. Remove the light guide acrylic and shading plate. Replace the light bar.
3. After replacement, assemble in reverse order.

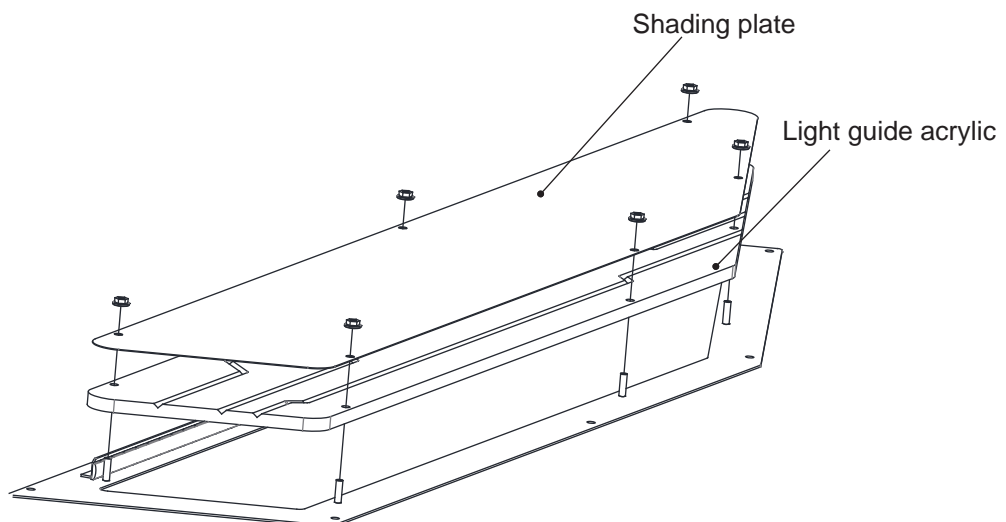

6. Assembly

6.1 Assembly tree diagram

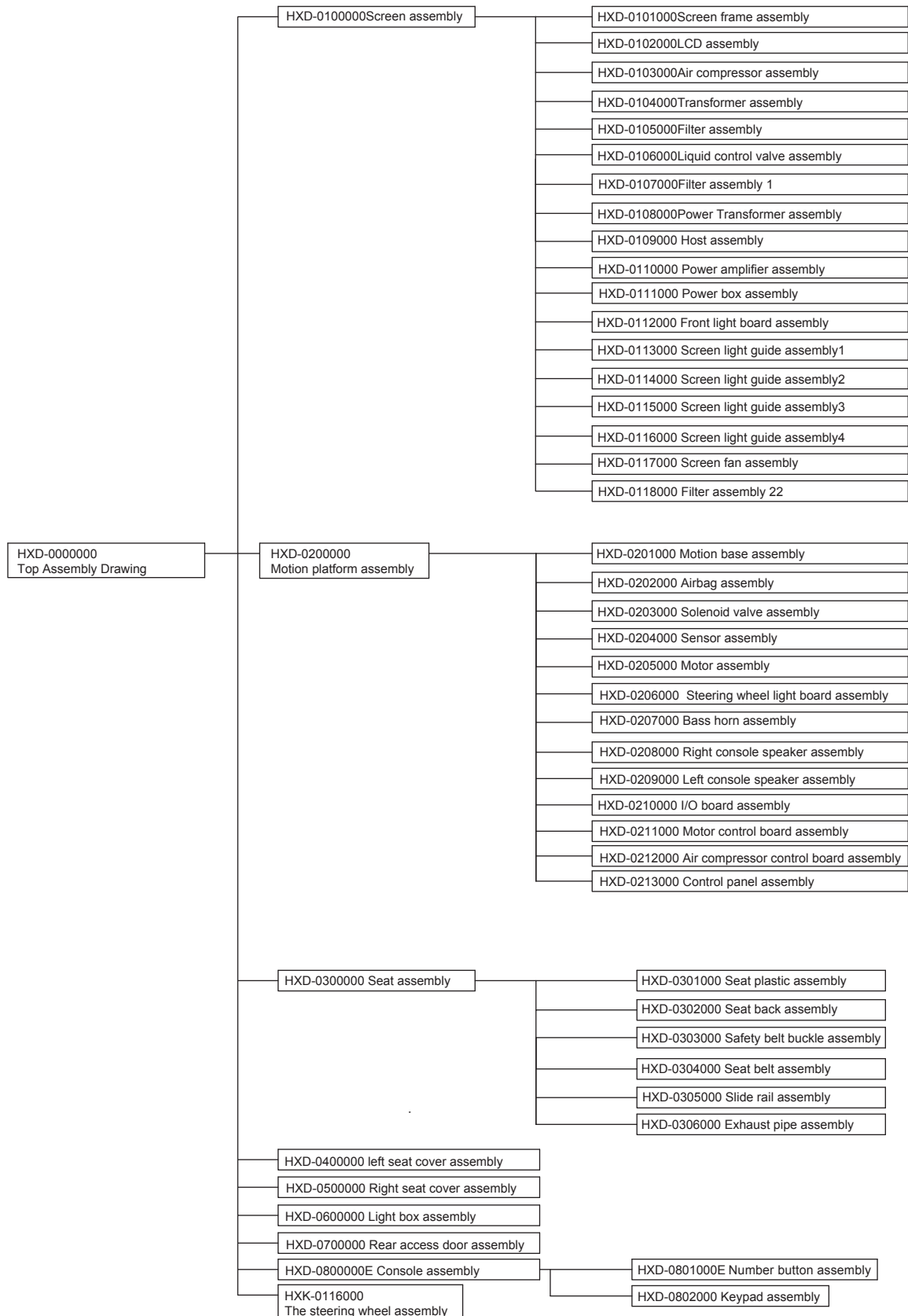

6.2 Top Assembly Drawing

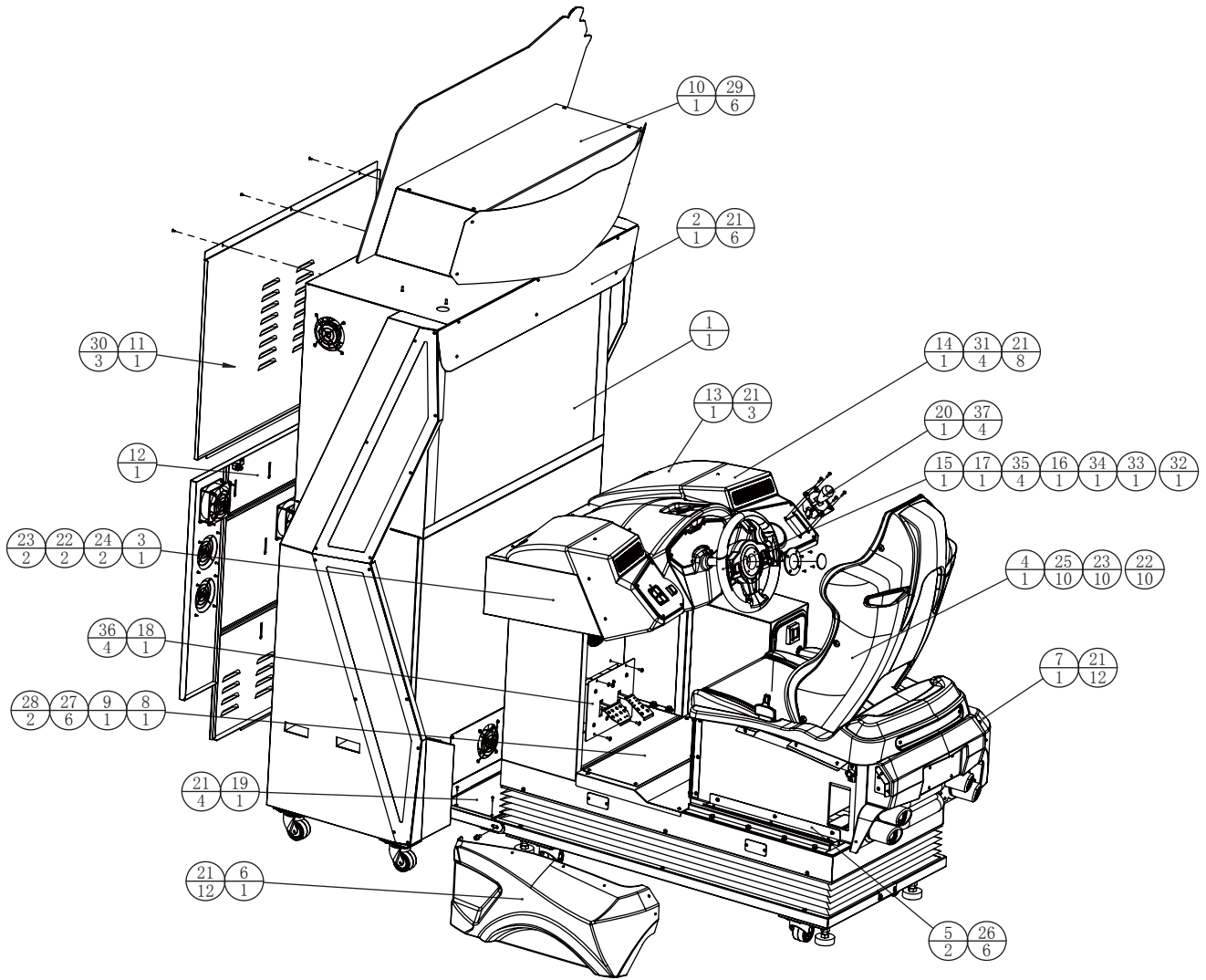

37		Hex socket cap screws	M5*20 (chrome)	4	1.6.LS154012
36		Cross the big flat head screw	M6*12 (black)	4	1.6.LS261021
35		Socket head cap screws	M3*8 (chrome)	4	1.6.LSF82011
34		Hexagon nut	M12 (black)	1	1.6.LM116013
33		Spring washer	M12 (black)	1	1.6.DP212011
32		Plain washers	φ12*φ23*2.0 (black)	1	1.6.DP112011
31		Hex socket cap screws	M4*16 (black)	4	1.6.LS154012
30		Cross the big flat head screw	M4*8 (black)	3	1.6.LS261021
29		Cross recessed fillister head three-combination screw	M6*16 (black)	6	1.6.LS862021
28		Hex socket cap screws	M5*40 (chrome)	2	1.6.LS154012
27		Hex socket cap screws	M5*12 (chrome)	6	1.6.LS154012
26		Cross recessed fillister head three-combination screw	M4*8 (black)	6	1.6.LS862021
25		External hex socket screw	M8*20 (black)	10	1.6.LSM86011
24		Socket head cap screws	M8*20 (black)	2	1.6.LSF82011
23		Spring washer	M8 (black)	12	1.6.DP212011
22		Plain washers	φ8*φ16*2.0 (black)	12	1.6.DP112011
21		Hex socket cap screws	M4*12 (black)	45	1.6.LS154012
20		Shift lever		1	2.1.IG19A010
19	HXD-0000A05	Connecting cover plate	SPCC-1.5T	1	1.1.IG19G00050
18	LT-0000000	Vertical induction pedal (LT)		1	2.1.AA03A080
17	HXK-P0011	Steering wheel acrylic	PMMA-3.0T	1	1.7.IG19A00180
16	HXK-0100C02	Steering wheel decorate plastic	ABS-1.5T	1	1.8.IG19A070
15	HXK-0116000	Steering wheel assembly		1	
14	HXD-0800000E	console assembly		1	
13	HXK-0100C01	Console rear cover	ABS-4.0T	1	1.8.IG19A050
12	HXD-0700000	Rear access door assembly		1	
11	HXD-0000A04	On screen repair	SPCC-1.5T	1	1.1.IG19G00040
10	HXD-0600000	Lightbox assembly		1	
9	HXD-0000A02	Pedal		1	1.1.IG19G00020
8	HXD-0000A03	Anti slide	SUS304-1.2T	1	1.1.IG19G00030
7	HXD-0500000	Right seat cover assembly		1	
6	HXD-0400000	Left seat cover assembly		1	
5	HXD-0000A01	Side cover plastic fixed hardware one	SECC-1.5T	2	1.1.IG19G00010
4	HXD-0300000	Seat assembly		1	
3	HXD-0200000	Motion platform assembly		1	
2	HXD-P0006	Front trim	PMMA-3.0T	1	1.7.IG19G00070
1	HXD-0100000	Screen assembly		1	
No.	Draw No.	Name	Material/Spec.	Qty.	Product Code

6.3 Screen assembly

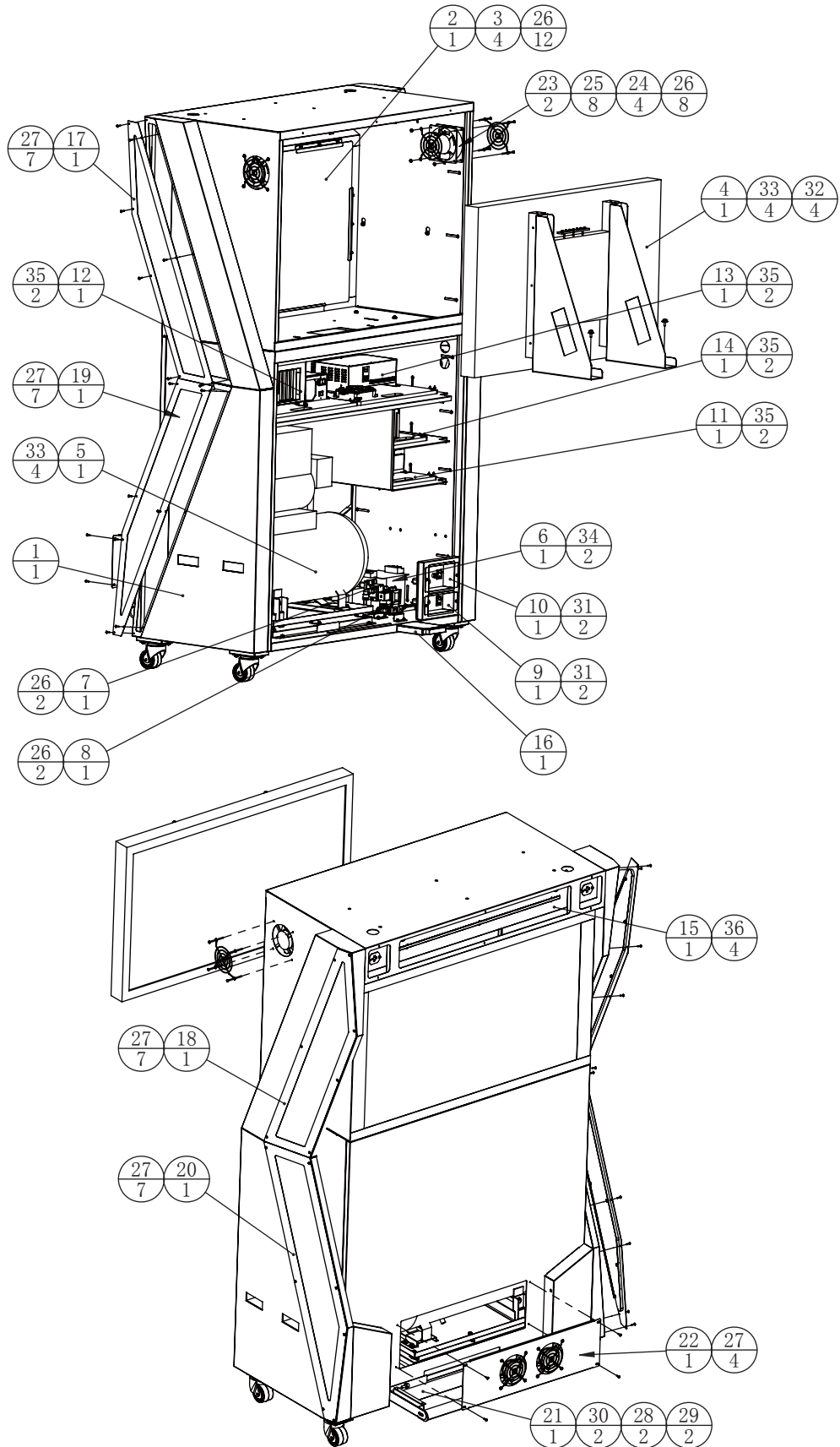

36		Cross recessed fillister head three-combination screw	M4*12 (black)	4	1.6.LS862021
35		Butterfly screws	M4*20 (chrome)	8	1.6.LSQ42012
34		Cross recessed fillister head three-combination screw	M4*16 (black)	2	1.6.LS862021
33		Cross recessed fillister head three-combination screw	M6*16 (black)	8	1.6.LS862021
32		Plain washers	Φ6*Φ20*2.0(black)	4	1.6.DP112011
31		Cross the big flat head screw	M4*12 (black)	4	1.6.LS261021
30		Socket head cap screws	M8*20 (black)	2	1.6.LSF82011
29		Spring washer	M8 (black)	2	1.6.DP212011
28		Plain washers	φ8*φ16*2.0(black)	2	1.6.DP112011
27		Hex socket cap screws	M4*12 (black)	32	1.6.LS154012
26		Hex head cap screw	M4 (color)	24	1.6.LM206013
25		Cross recessed cheese head screws	M4*60 (black)	8	1.6.LS746011
24		Fan cover	120*120	4	1.4.FS300020
23		Fan with bearing	120*120/AC110V	2	1.4.FS200042
22	HXD-0117000	Screen fan assembly		1	
21	HXD-0100A03	Platform connecting seat		1	1.1.IG19G00080
20	HXD-0116000	Screen light guide assembly 4		1	
19	HXD-0115000	Screen light guide assembly 3		1	
18	HXD-0114000	Screen light guide assembly 2		1	
17	HXD-0113000	Screen light guide assembly 1		1	
16	HXD-0100A02	Collecting trough		1	1.1.IG19G00070
15	HXD-0112000	Front light board assembly		1	
14	HXD-0111000	Power box assembly		1	
13	HXD-0110000	Power amplifier assembly		1	
12	HXD-0109000	Host assembly		1	
11	HXD-0108000	Power transformer assembly		1	
10	HXD-0118000	Filter assembly 2		1	
9	HXD-0107000	Filter assembly 1		1	
8	HXD-0106000	Liquid control valve assembly		1	
7	HXD-0105000	Filter assembly		1	
6	HXD-0104000	Transformer assembly		1	
5	HXD-0103000	Air compressor assembly		1	
4	HXD-0102000	LCD assembly		1	
3	HXD-0100A01	Glass plate	SECC-1.0T	4	1.1.IG19G00060
2	WAH-0000C05	42" led screen glass a	glass-5.0T	1	1.8.AA030050
1	HXD-0101000	Screen frame assembly		1	1.1.IG19G00060
No.	Draw No.	Name	Material/Spec.	Qty.	Product Code

6.3.1 Screen frame assembly

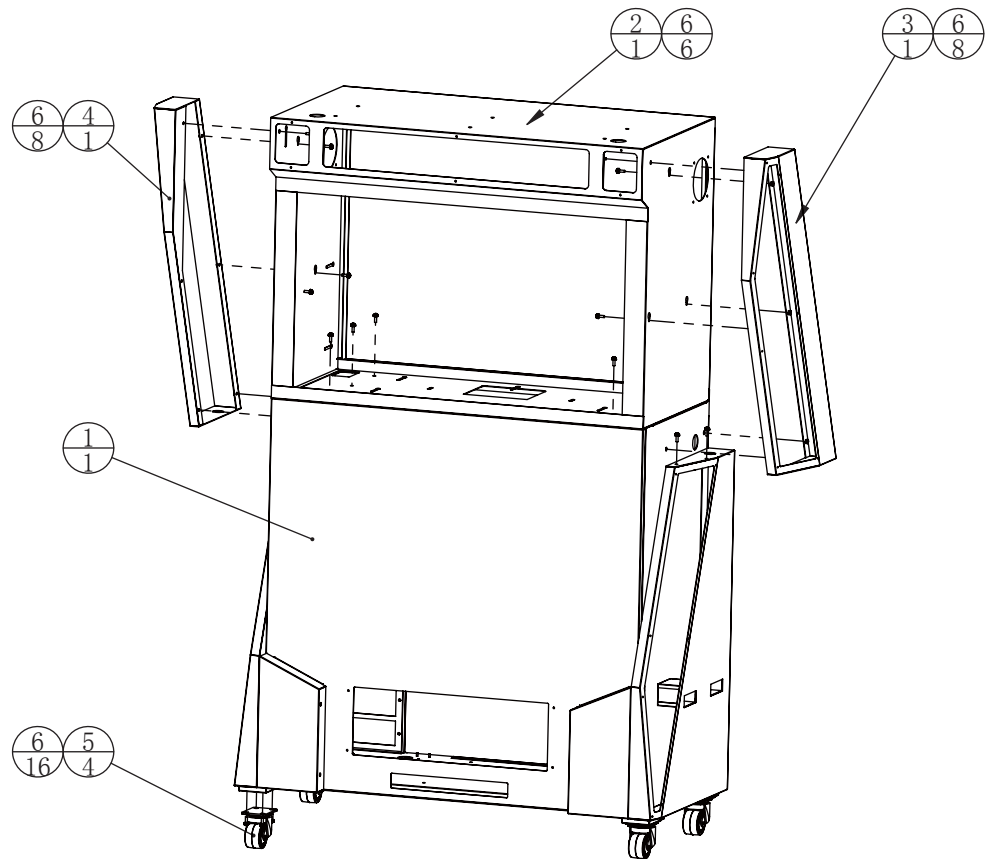

6		Cross recessed fillister head three-combination screw	M6*16 (black)	38	1.6.LS862021
5		Casters	2.5"	4	1.4.JL302520
4	HXD-0101A04	The second article screen side light		1	1.1.IG19G00120
3	HXD-0101A03	The article screen side light		1	1.1.IG19G00110
2	HXD-0101A02	The screen box body		1	1.1.IG19G00100
1	HXD-0101A01	Under the screen box body		1	1.1.IG19G00090
No.	Draw No.	Name	Material/Spec.	Qty.	Product Code

6.3.2 LCD assembly

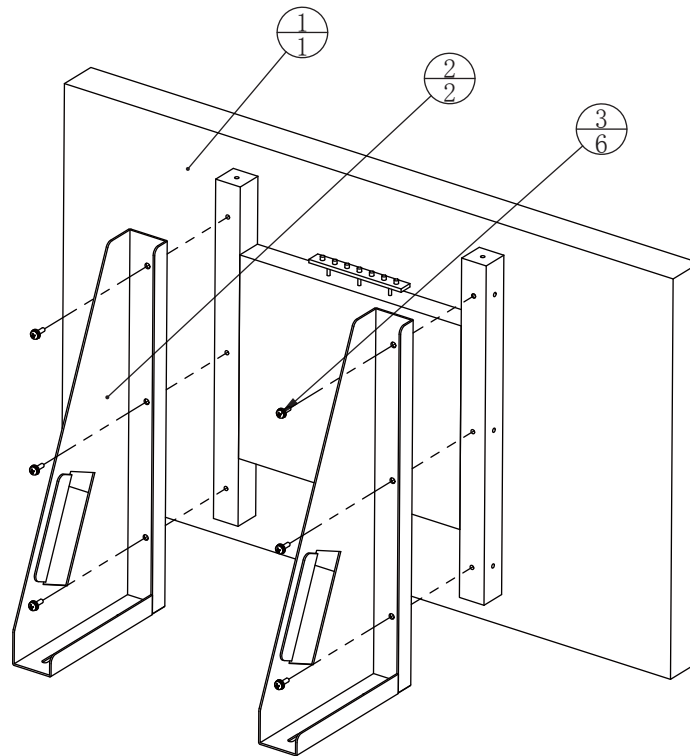

3		Cross recessed fillister head three-combination screw	M6*16 (black)	6	1.6.LS862021
2	HXD-0102A01	LCD Bracket	SPCC-2.5T	2	1.1.IG19G00130
1		42" led screen with frame		1	1.4.XS404250
No.	Draw No.	Name	Material/Spec.	Qty.	Product Code

6.3.3 Air compressor assembly

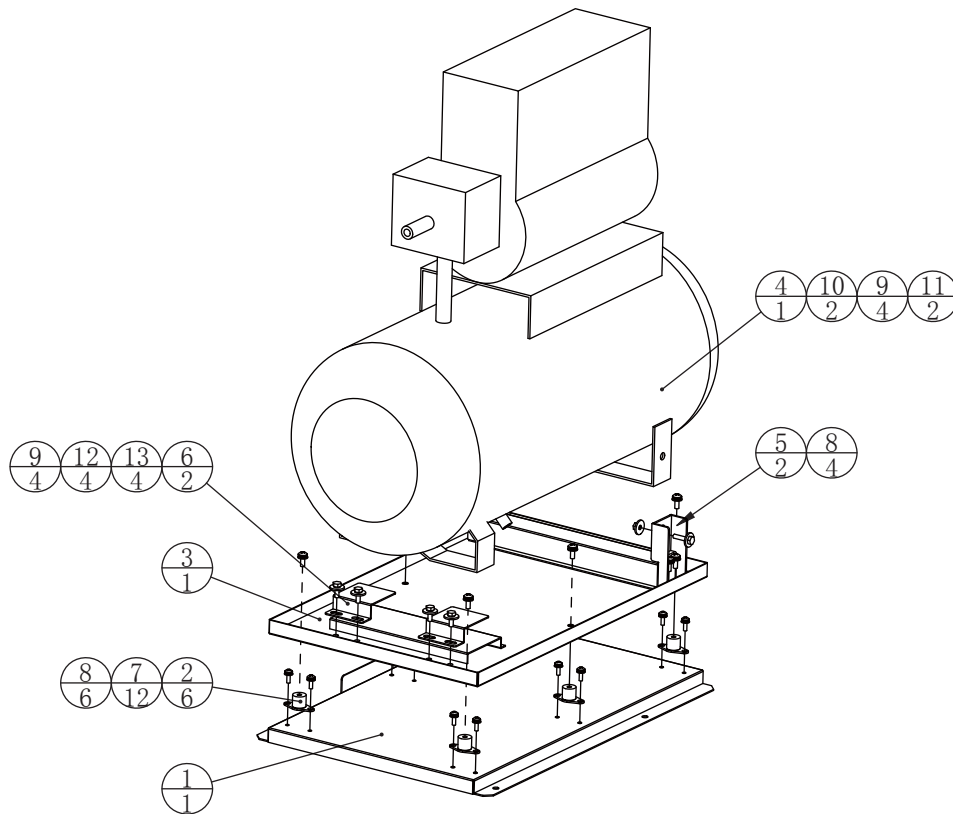

13		External hex socket screw	M6*16 (black)	4	1.6.LSM86011
12		Spring washer	M6 (black)	4	1.6.DP212011
11		Self-Locking Nuts	M6 (Galvanization)	2	1.6.LM308014
10		External hex socket screw	M6*25 (black)	2	1.6.LSM86011
9		Plain washers	Φ6*Φ20*2.0 (black)	8	1.6.DP112011
8		Cross recessed fillister head three-combination screw	M6*12 (black)	10	1.6.LS862021
7		Cross recessed fillister head three-combination screw	M5*12 (black)	12	1.6.LS862021
6	HXD-0103A03	The weight of air compressor	SPCC-1.5T	2	1.1.IG19G00160
5	SRH-0108A02	air compressor fixed iron	SPCC-2.5T	2	1.1.WA16C00230
4		Air compressor	S10(AC220V)	1	1.4.KY100030
3	HXD-0103A02	Air compressor brackets		1	1.1.IG19G00150
2		Lanhe shaped foot shock		6	1.8.AA000250
1	HXD-0103A01	Air compressor shockproof base		1	1.1.IG19G00140
No.	Draw No.	Name	Material/Spec.	Qty.	Product Code

6.3.4 Transformer assembly

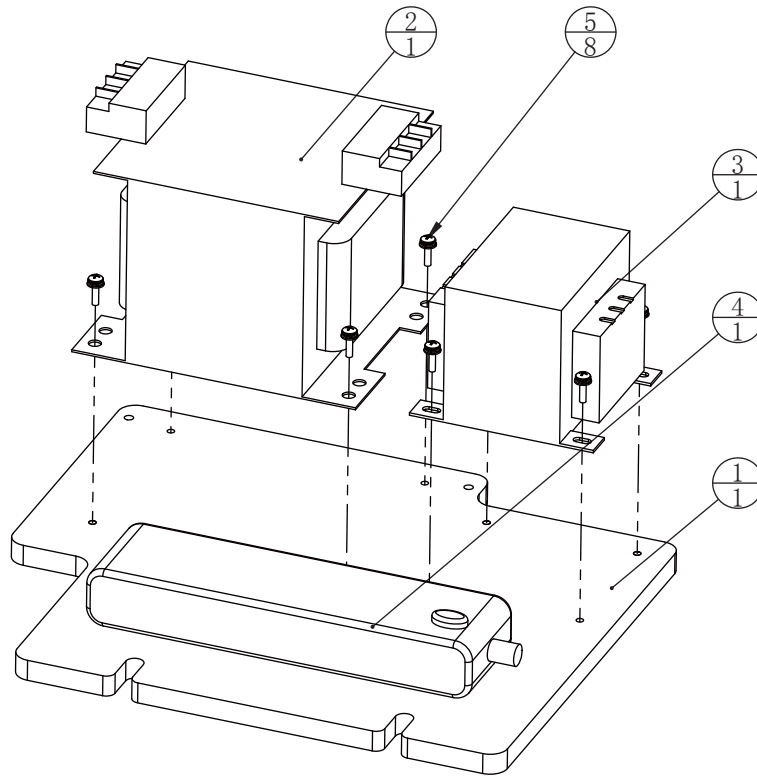

5		Cross recessed fillister head three-combination screw	M4*12 (black)	8	1.6.LS862021
4		Multi socket	GN-K014	1	1.5.XC202020
3		Transformer	200W AC220/110V 16V-0V-16V	1	1.4.BY111010
2		Transformer	AC220VorAC110V/AC 11 0V 1100VA	1	1.4.BY111010
1	HXD-0104B01	Transformer carriage	MDF-12.0T	1	1.2.IG19G00010
No.	Draw No.	Name	Material/Spec.	Qty.	Product Code

6.3.5 Filter assembly

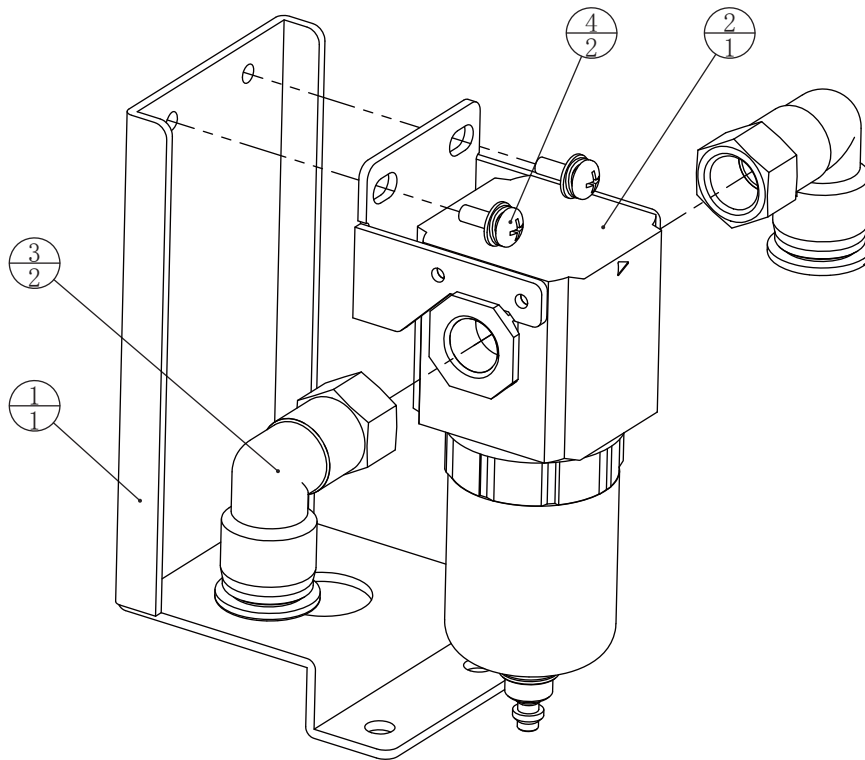

4		Cross recessed fillister head three-combination screw	M4*8 (black)	2	1.6.LS862021
3		L type screw thread connector	APL10-02	2	1.4.JG072100
2		Clean Air Component	CF200-08	1	1.4.LB200020
1	SRH-0113A01			1	
No.	Draw No.	Name	Material/Spec.	Qty.	Product Code

6.3.6 Liquid control valve assembly

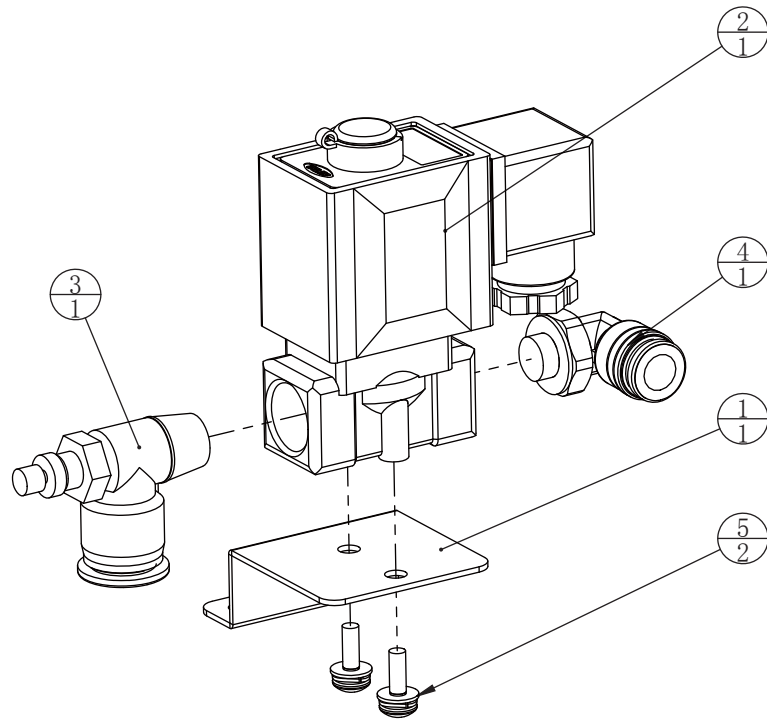

5		Cross recessed fillister head three-combination screw	M5*12 (black)	2	1.6.LS862021
4		L type screw thread connector	APL10-04	1	1.4.JG072100
3		One-way throttle valve - pipe connector	ASL10-04B	1	1.4.JG09A020
2		Fluids control valve	2KW050-15-F	1	1.4.JG09A040
1	HXD-0106A01	Two mouth solenoid valve seat	SPCC-1.5T	1	1.1.IG19G00170
No.	Draw No.	Name	Material/Spec.	Qty.	Product Code

6.3.7 Filter assembly 1

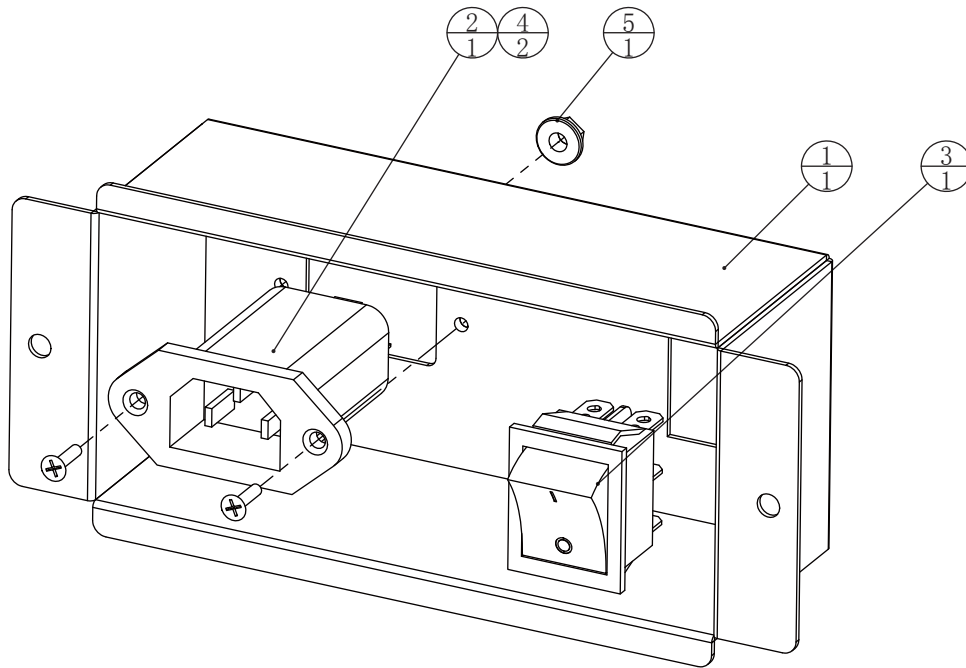

5		Hex head cap screw	M4 (color)	1	1.6.LM206013
4		Cross recessed countersunk head screws	M3*10 (black)	2	1.6.LSC41021
3		Rocker switch	4P KCD7-2211N	1	1.4.SW604010
2		Filter	YB11A2-15A-Q	1	1.4.LB100080
1	HXD-0107A01	The power supply box 2	SPCC-1.2T	1	1.1.IG19G00180
No.	Draw No.	Name	Material/Spec.	Qty.	Product Code

6.3.8 Power Transformer assembly

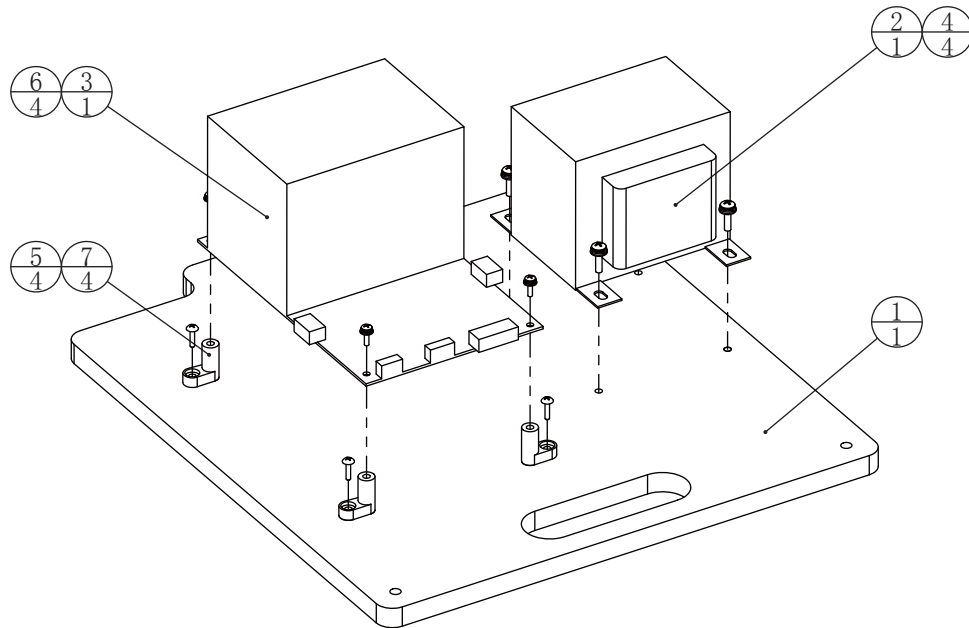

7		L-holder	M3mm	4	1.9.LX103010
6		Cross recessed fillister head three-combination screw	M3*8 (chrome)	4	1.6.LS862021
5		Cross the big flat head self-drilling screw	M3*12 (chrome)	4	1.6.LS341041
4		Cross recessed fillister head three-combination screw	M4*12 (black)	4	1.6.LS862021
3		Amplifier	HIT-AP-2WAY-4OHM S-50W	1	1.4.GF200020
2		Transformer	220V/110V 70V-10V/ 3A	1	1.4.BY111010
1	HXD-0108B01	The power amplifier	MDF-12.0T	1	1.2.IG19G00020
No.	Draw No.	Name	Material/Spec.	Qty.	Product Code

6.3.9 Host assembly

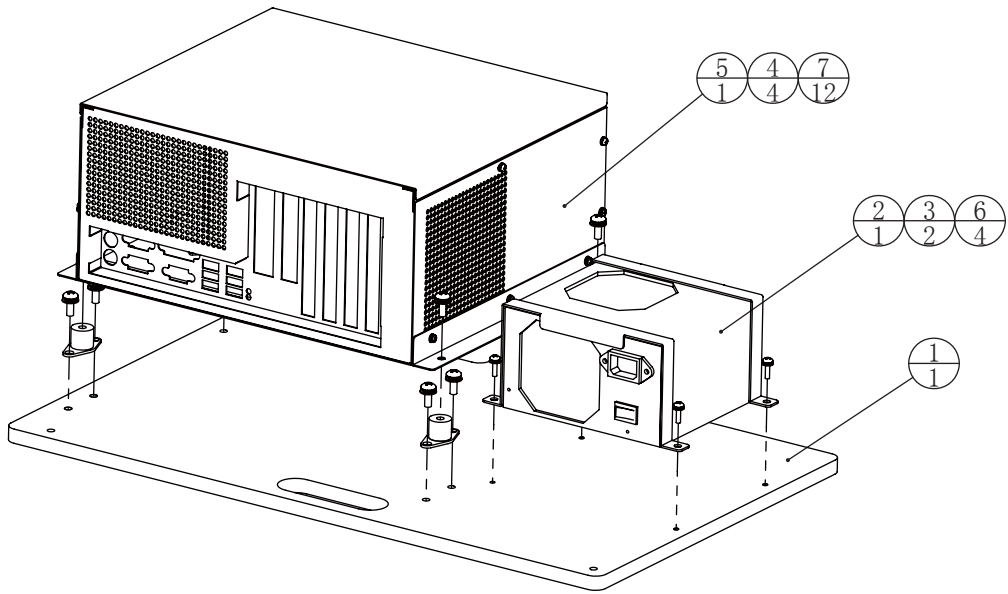

7		Cross recessed fillister head three-combination screw	M6*12 (black)	12	1.6.LS862021
6		Cross recessed fillister head three-combination screw	M4*12 (black)	4	1.6.LS862021
5	HXD-0109000A	HXD Host		1	2.1.IG19G010#
4		Lanhe shaped foot shock		4	1.8.AA000250
3	HXK-0102A01	Host power supply fixing plate	SPCC-1.5T	2	1.1.IG19A00240
2		Atx power supply	S12II-520Bronze	1	1.4.DY130090
1	HXD-0109B01	Main carriage	MDF-12.0T	1	1.2.IG19G00030
No.	Draw No.	Name	Material/Spec.	Qty.	Product Code

6.3.10 Power amplifier assembly

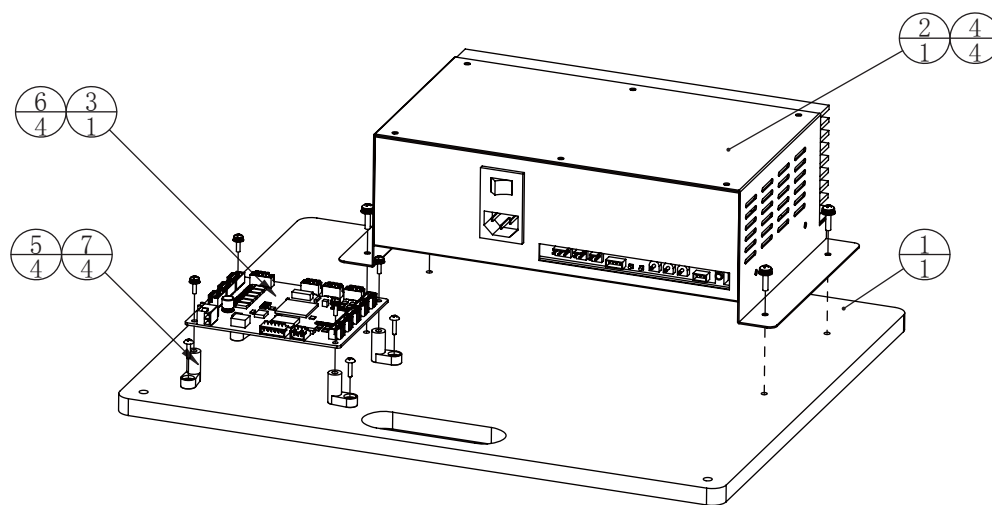

7		L-holder	M3mm	4	1.9.LX103010
6		Cross recessed fillister head three-combination screw	M3*8 (chrome)	4	1.6.LS862021
5		Cross the big flat head self-drilling screw	M3*12 (chrome)	4	1.6.LS341041
4		Cross recessed fillister head three-combination screw	M4*12 (black)	4	1.6.LS862021
3		Light control panel		1	1.3.IG19G00020#
2		4.1 amplifier	JK-OP-03	1	1.4.GF100022
1	HXD-0110B01	The 4.1 power amplifier	MDF-12.0T	1	1.2.IG19G00040
No.	Draw No.	Name	Material/Spec.	Qty.	Product Code

6.3.11 Power box assembly

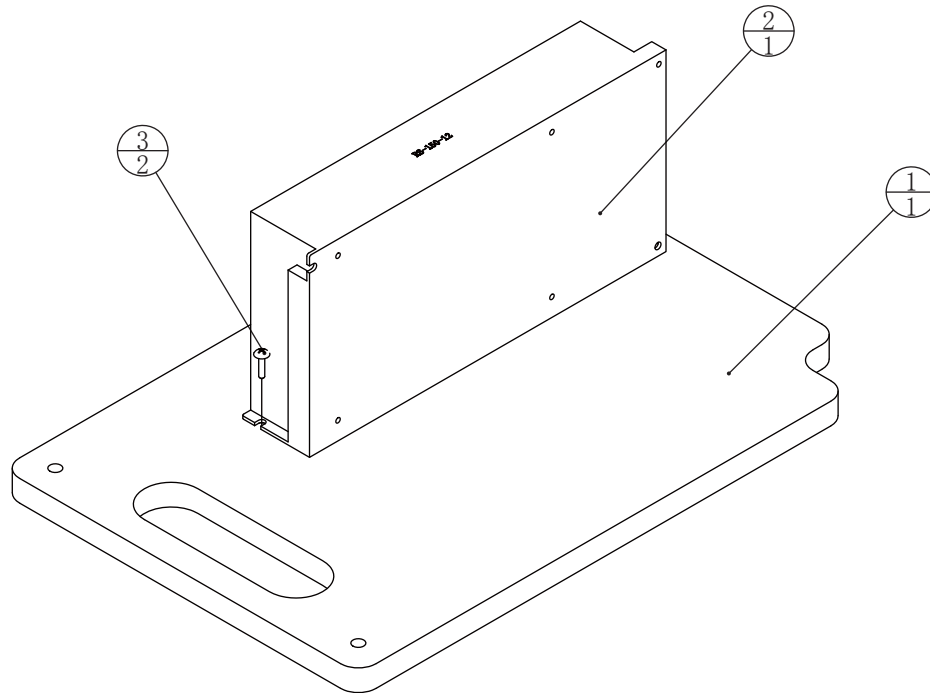

3		Cross the big flat head self-drilling screw	M3*12 (chrome)	2	1.6.LS331022
2		Power supply	RS-150-12	1	1.4.DY06A010
1	HXD-0111B01	Power strip	MDF-12.0T	1	1.2.IG19G00050
No.	Draw No.	Name	Material/Spec.	Qty.	Product Code

6.3.12 Front light board assembly

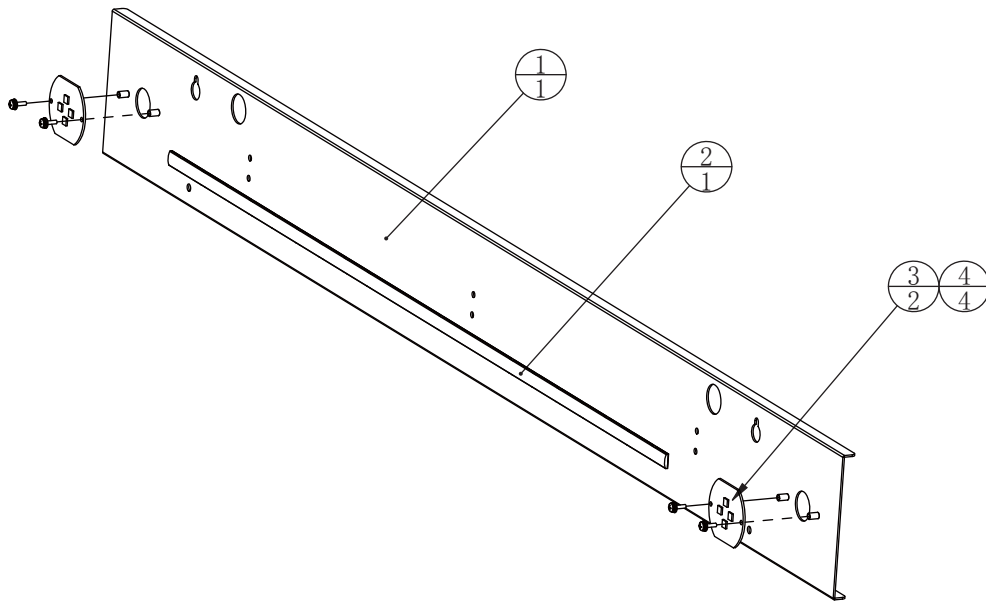

4		Cross recessed fillister head three-combination screw	M3*8 (chrome)	4	1.6.LS830022
3		Head tail light board	HR-CQ-1192-00	2	1.4.IC902440
2		5050 strip light (lpd6803chip)	DC12V RGB30 L=700mm	1	1.4.ZM9E1078
1	HXD-0112A01	Screen article lamp holder	SECC-1.2T	1	1.1.IG19G00190
No.	Draw No.	Name	Material/Spec.	Qty.	Product Code

6.3.13 Screen light guide assembly 1

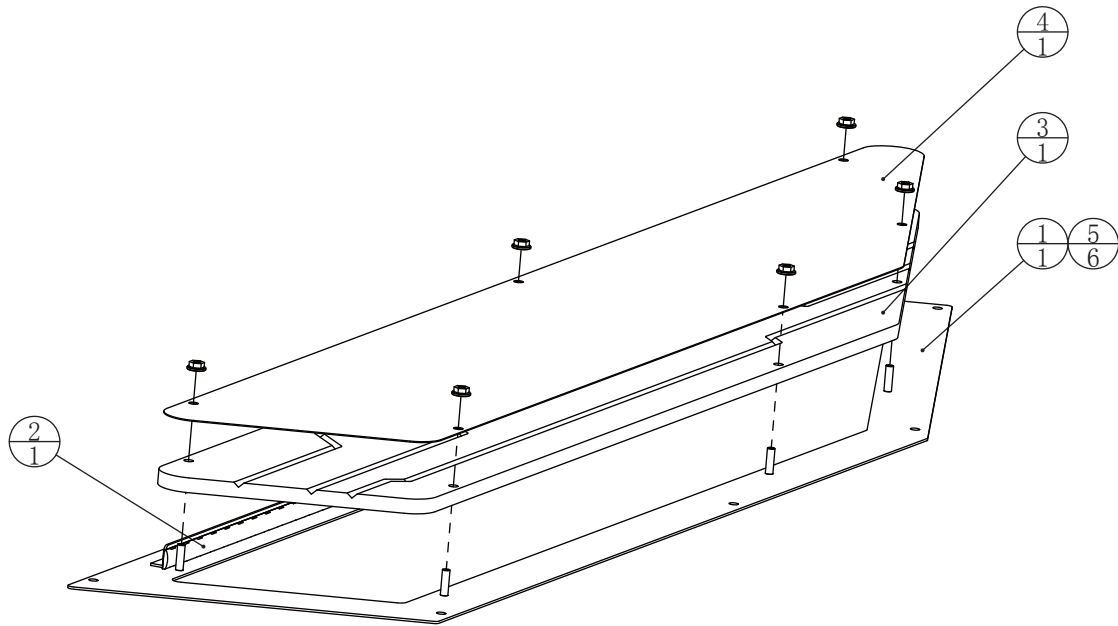

5		Hex head cap screw	M4 (color)	6	1.6.LM204013
4	HXD-0113D02	The light guide plate acrylic	acrylic-0.5T	1	1.7.IG19G00040
3	HXD-P0009	The screen light guide plate(1)	PMMA-8.0T	1	1.7.IG19G00100
2		5050 strip light (Ipd6803chip)	DC12V RGB30 L=800mm	1	1.4.ZM9E0A30
1	HXD-0113A01	The acrylic screen a fixed plate		1	1.1.IG19G00200
No.	Draw No.	Name	Material/Spec.	Qty.	Product Code

6.3.14 Screen light guide assembly 2

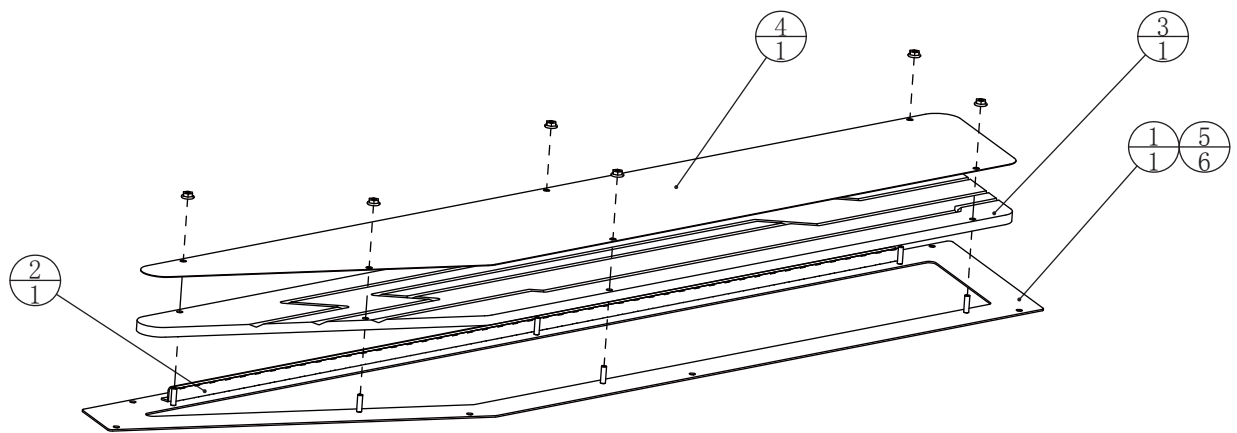

5		Hex head cap screw	M4 (color)	6	1.6.LM204013
4	HXD-0113D02	The light guide plate acrylic	acrylic-0.5T	1	1.7.IG19G00040
3	HXD-P0010	The screen light guide plate(2)	PMMA-8.0T	1	1.7.IG19G00110
2		5050 strip light (lpd6803chip)	DC12V RGB30 L=800mm	1	1.4.ZM9E0A30
1	HXD-0114A01	A fixed screen acrylic plate		1	1.1.IG19G00210
No.	Draw No.	Name	Material/Spec.	Qty.	Product Code

6.3.15 Screen light guide assembly 3

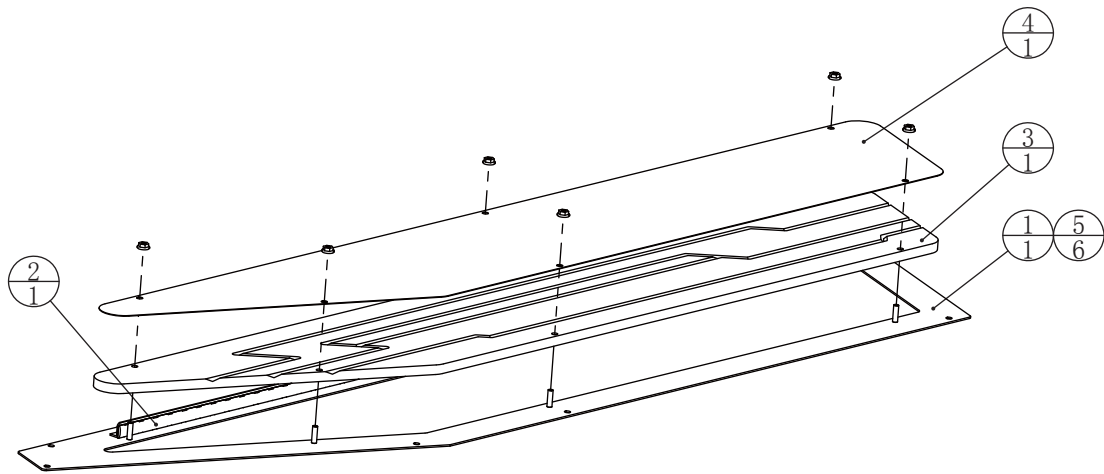

5		Hex head cap screw	M4 (color)	6	1.6.LM204013
4	HXD-0113D02	The light guide plate acrylic	acrylic-0.5T	1	1.7.IG19G00040
3	HXD-P0010	The screen light guide plate(2)	PMMA-8.0T	1	1.7.IG19G00110
2		5050 strip light (lpd6803chip)	DC12V RGB30 L=800mm	1	1.4.ZM9E0A30
1	HXD-0115A01	Two screen acrylic plate		1	1.1.IG19G00220
No.	Draw No.	Name	Material/Spec.	Qty.	Product Code

6.3.16 Screen light guide assembly 4

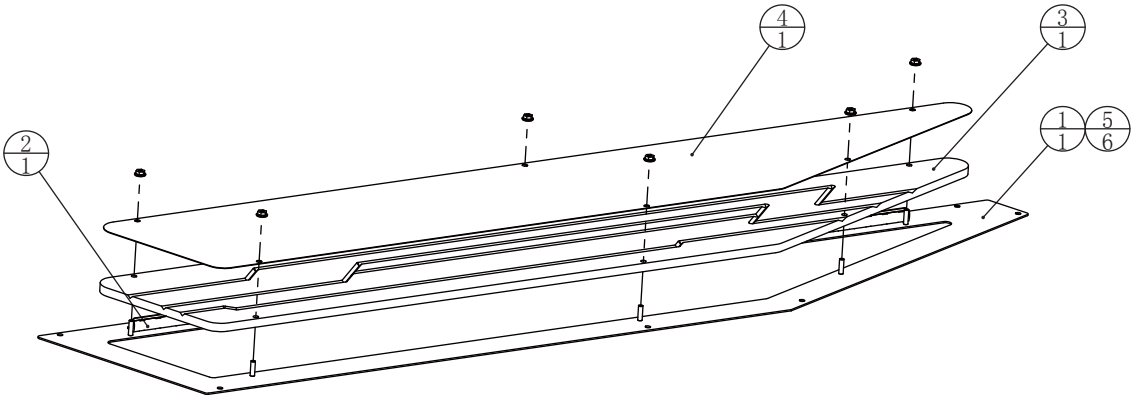

5		Hex head cap screw	M4 (color)	6	1.6.LM204013
4	HXD-0113D02	The light guide plate acrylic	acrylic-0.5T	1	1.7.IG19G00040
3	HXD-P0009	The screen light guide plate(1)	PMMA-8.0T	1	1.7.IG19G00100
2		5050 strip light (Ipd6803chip)	DC12V RGB30 L=800mm	1	1.4.ZM9E0A30
1	HXD-0116A01	Screen lamp holder three		1	1.1.IG19G00230
No.	Draw No.	Name	Material/Spec.	Qty.	Product Code

6.3.17 Screen fan assembly

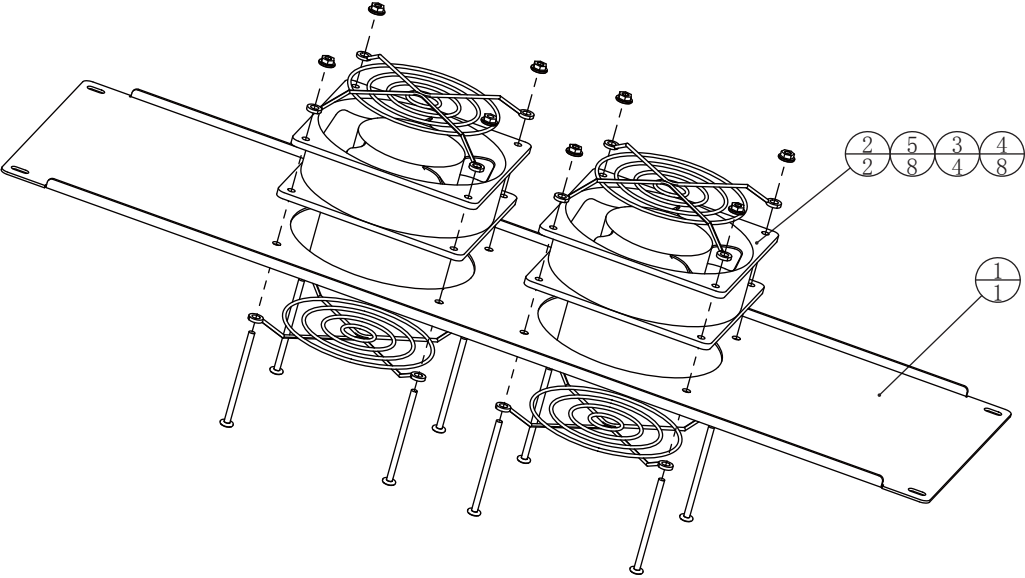

5		Hex head cap screw	M4 (color)	8	1.6.LM204013
4		Cross recessed cheese head screws	M4*60 (black)	8	1.6.LS746011
3		Fan cover	120*120	4	1.4.FS300020
2		Fan with bearing	120*120/AC110V	2	1.4.FS200042
1	HXD-0117A01	Screen lamp holder four	SPCC-1.5T	1	1.1.IG19G00240
No.	Draw No.	Name	Material/Spec.	Qty.	Product Code

6.3.18 Filter assembly 2

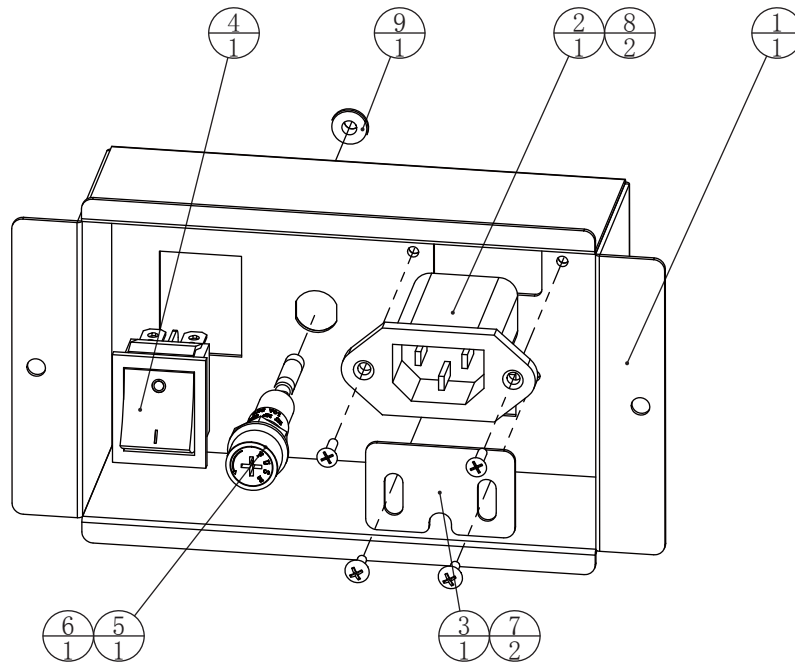

9		Hex head cap screw	M4 (color)	1	1.6.LM204013
8		Cross recessed countersunk head screws	M3*10 (black)	2	1.6.LSC31011
7		Cross the big flat head screw	M3*8 (black)	2	1.6.LS230081
6		Fuse tube	F6A 5x20 250V	1	1.4.BX106020
5		Fuse unit	MF527A	1	1.4.BX300010
4		Rocker switch	4P KCD7-2211N	1	1.4.SW604010
3	HXD-0118A02	Screen	SPCC-1.0T	1	1.1.IG19G00260
2		Filter	YB11A2-15A-Q	1	1.4.LB100080
1	HXD-0118A01	The power supply box 1	SPCC-1.2T	1	1.1.IG19G00250
No.	Draw No.	Name	Material/Spec.	Qty.	Product Code

6.4 Motion platform assembly

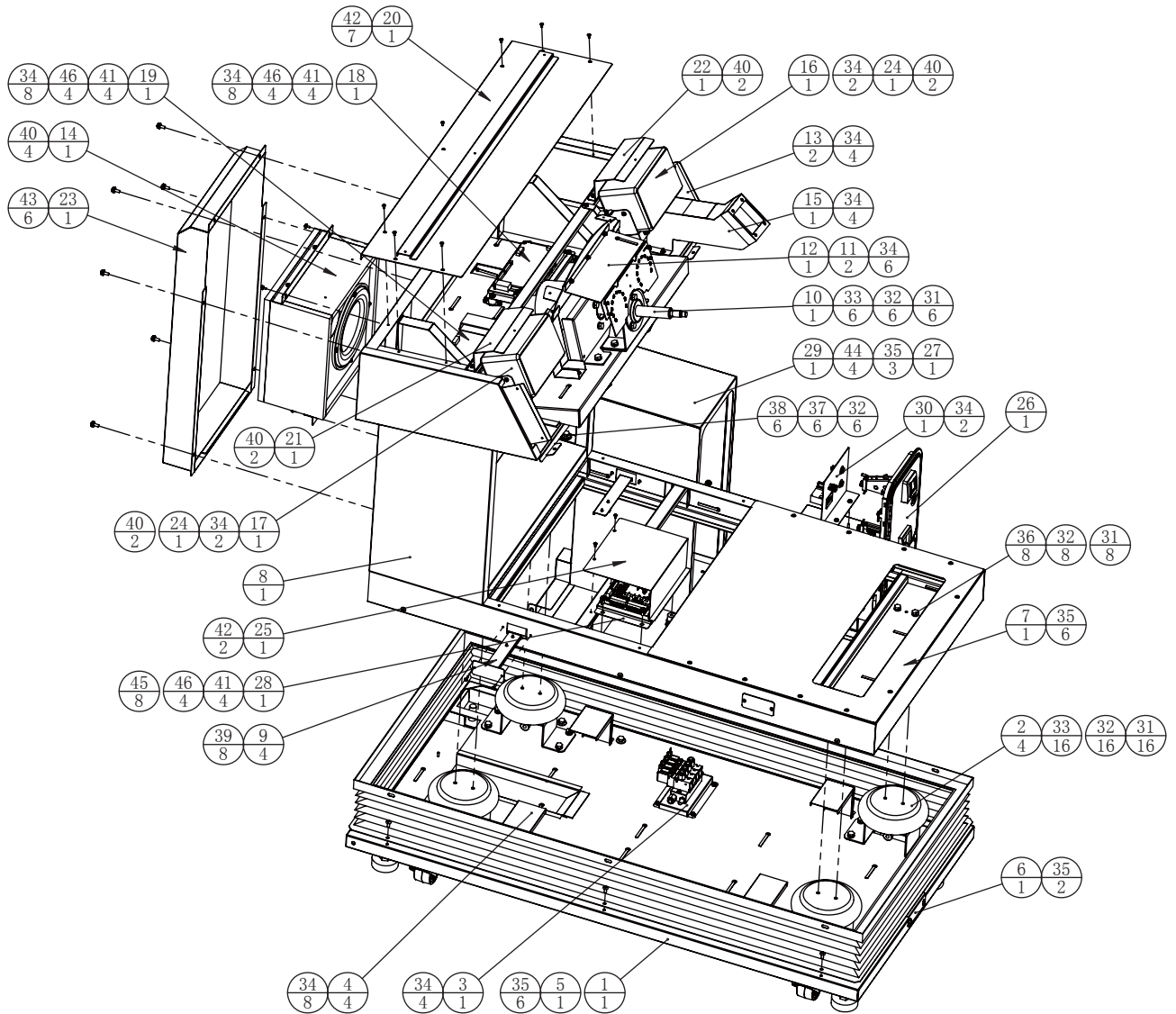

46		Lanhe shaped foot shock		12	
45		Hex head cap screw	M5 (color)	8	1.6.LM205013
44		Hex head cap screw	M6 (color)	4	1.6.LM206013
43		Cross recessed fillister head three-combination screw	M6*12 (black)	6	1.6.LS861021
42		Cross the big flat head screw	M4*8 (black)	9	1.6.LS240021
41		Cross recessed fillister head three-combination screw	M6*12 (chrome)	12	1.6.LS861022
40		Cross recessed fillister head three-combination screw	M4*8 (black)	12	1.6.LS840021
39		Cross the big flat head screw	M4*12 (black)	8	1.6.LS241021
38		External hex socket screw	M8*60 (black)	6	1.6.LSM86011
37		Plain washers	φ8*φ22*2.0(black)	6	1.6.DP108031
36		External hex socket screw	M8*16 (black)	8	1.6.LSM81021
35		Cross the big flat head screw	M6*12 (black)	17	1.6.LS261021
34		Hex head cap screw	M4 (color)	48	1.6.LM204013
33		External hex socket screw	M8*20 (black)	22	1.6.LSM82011
32		Spring washer	M8 (black)	36	1.6.DP208011
31		Plain washers	φ8*φ16*2.0(black)	30	1.6.DP108011
30	HXD-0213000	Control panel assembly		1	
29	HXD-0200A14	Cashbox		1	1.1.IG19G00400
28	HXD-0212000	Air compressor control board assembl		1	
27	HXD-0200A13	I walk the line cover		1	1.1.IG19G00390
26	TYM-0000000A	Single coin door frame		1	
25	HXD-0200D01	Waterproof cover plate	PVC-1.0T	1	1.7.IG19G00010
24	HXD-0200A11	Console speakers to enhance hardware	SECC-1.5T	2	1.1.IG19G00370
23	HXD-0200A12	Console rear cover	SPCC-1.2T	1	1.8.IG19A050
22	HXD-0200A10	Back cover right support plate	SECC-1.5T	1	1.1.IG19G00360
21	HXD-0200A09	The console cover left supporting board	SECC-1.5T	1	1.1.IG19G00350
20	HXD-0200A08	Control panel		1	1.1.IG19G00340
19	HXD-0211000	Motor control board assembly		1	
18	HXD-0210000	IO board assembly		1	
17	HXD-0209000	Left console speaker assembly		1	
16	HXD-0208000	Right console speaker assembly		1	
15	HXD-0200A07	The gear rod fixing seat		1	1.1.IG19G00330
14	HXD-0207000	Bass horn assembly		1	
13	HXD-0200A06	The front cover plate support control	SECC-1.5T	2	1.1.IG19G00320
12	HXD-0206000	Steering wheel light board assembly		1	
11	HXD-0200A05	Instrument light board support frame	SPCC-1.5T	2	1.1.IG19G00310
10	HXD-0205000	Motor assembly		1	
9	HXD-0204000	Sensor assembly		4	
8	HXD-0200A04	The steering wheel control pedestal		1	1.1.IG19G00300
7	HXD-0200A03	Dynamic attendance platform		1	1.1.IG19G00290
6	HXD-0200A02	Dust cover plate	SPCC-1.5T	1	1.1.IG19G00280
5	SRH-0200A01	dust cover		1	1.1.WA16C00320
4	HXD-0200A01	Sensor reflector	SPCC-1.0T	4	1.1.IG19G00270
3	HXD-0203000	Solenoid valve assembly		1	
2	HXD-0202000	Airbag assembly		4	
1	HXD-0201000	Motion base assembly		1	
No.	Draw No.	Name	Material/Spec.	Qty.	Product Code

6.4.1 Motion base assembly

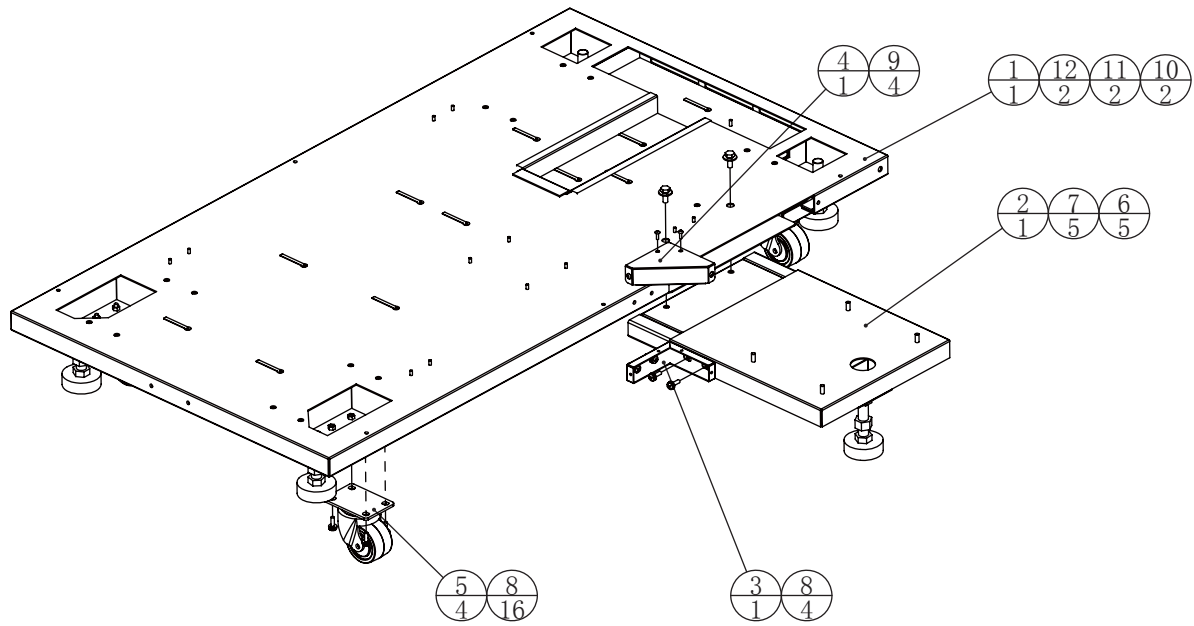

12		External hex socket screw	M8*20 (black)	2	1.6.LSM82011
11		Spring washer	M8 (black)	2	1.6.DP208011
10		Plain washers	φ8*φ22*2.0(black)	2	1.6.DP108031
9		Hex socket cap screws	M4*12 (black)	4	1.6.LS141021
8		Cross recessed fillister head three-combination screw	M6*16 (black)	20	1.6.LS861031
7		Hexagon nut	M16 (color)	5	1.6.LM116013
6		Anchor bolt (rubber bottom)	M16*100(color)	5	1.6.LSV99014
5		Casters	2.5"	4	1.4.JL302520
4	HXD-0201A04	Support cover plate	SPCC-1.5T	1	1.1.IG19G00440
3	HXD-0201A03	Support frame	SPCC-1.5T	1	1.1.IG19G00430
2	HXD-0201A02	The box base		1	1.1.IG19G00420
1	HXD-0201A01	Seat under dynamic platform		1	1.1.IG19G00410
No.	Draw No.	Name	Material/Spec.	Qty.	Product Code

6.4.2 Airbag assembly

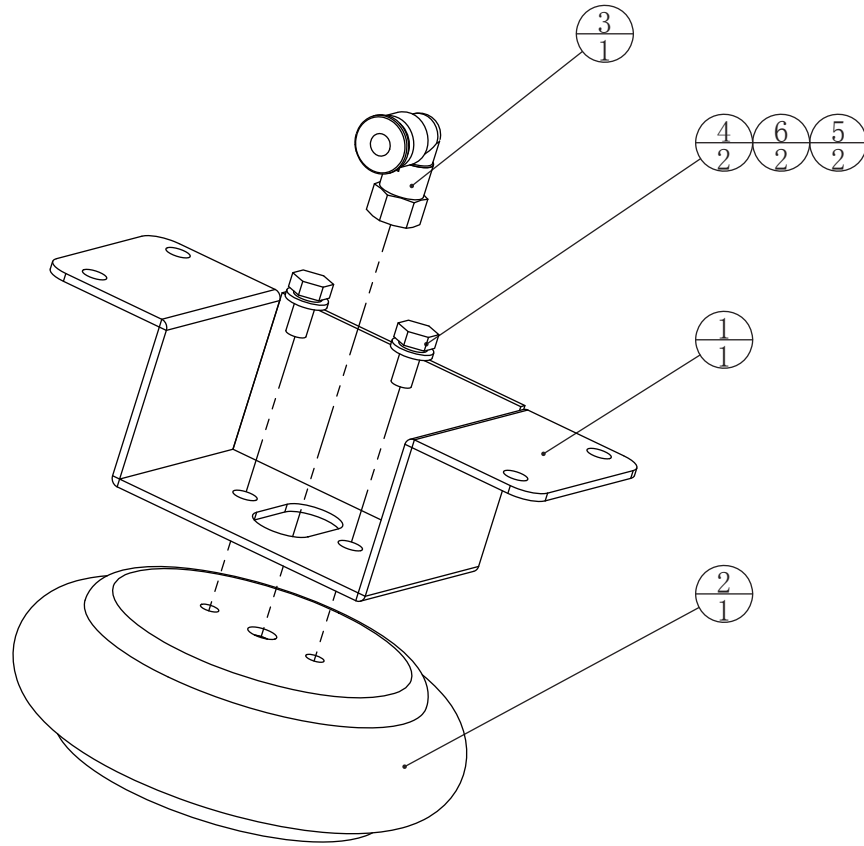

6		Spring washer	M8 (black)	2	1.6.DP208011
5		Plain washers	$\phi 8 \times \phi 16 \times 2.0$ (black)	2	1.6.DP108011
4		External hex socket screw	M8*16 (black)	2	1.6.LSM81021
3		L type screw thread connector	APL8-02	1	1.4.JG072120
2		Air bag	1B5002	1	1.4.QL000020
1	HXD-0202A01	Air spring seat	SPCC-3.0T	1	1.1.IG19G00450
No.	Draw No.	Name	Material/Spec.	Qty.	Product Code

6.4.3 Solenoid valve assembly

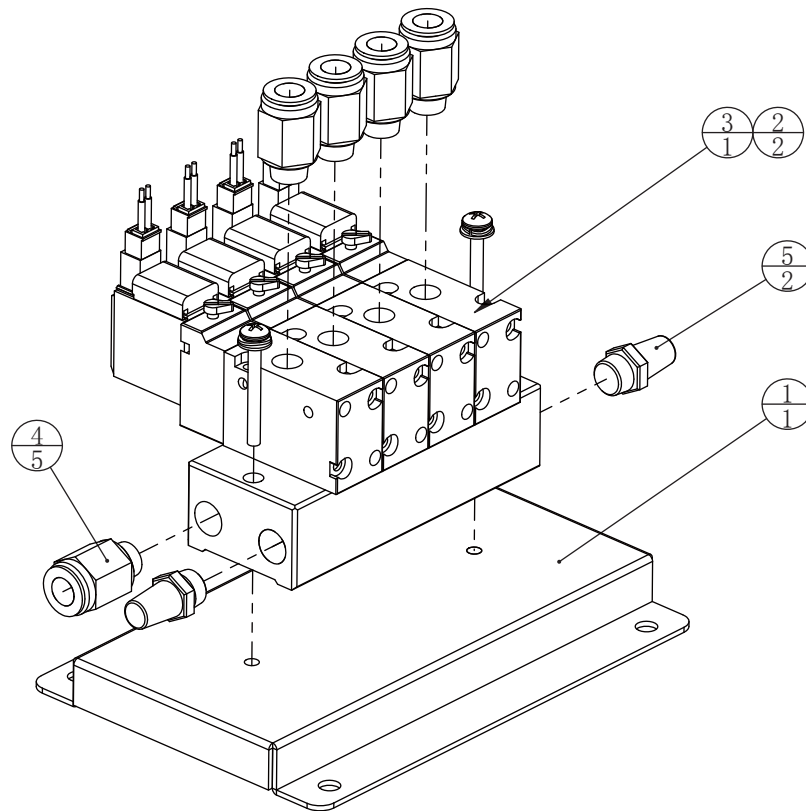

5		Copper silencer	SL-01	2	1.4.YSE00030
4		Vertical joint	SQC 8-01	5	1.9.JG034030
3		Solenoid valve	SMU-7101-NC-DC12-T- M4	1	
2		Cross recessed fillister head three-combination screw	M4*30 (chrome)	2	1.6.LS843012
1	HXD-0203A01	Electromagnetic valve seat	SECC-1.5T	1	1.1.IG19G00460
No.	Draw No.	Name	Material/Spec.	Qty.	Product Code

6.4.4 Sensor assembly

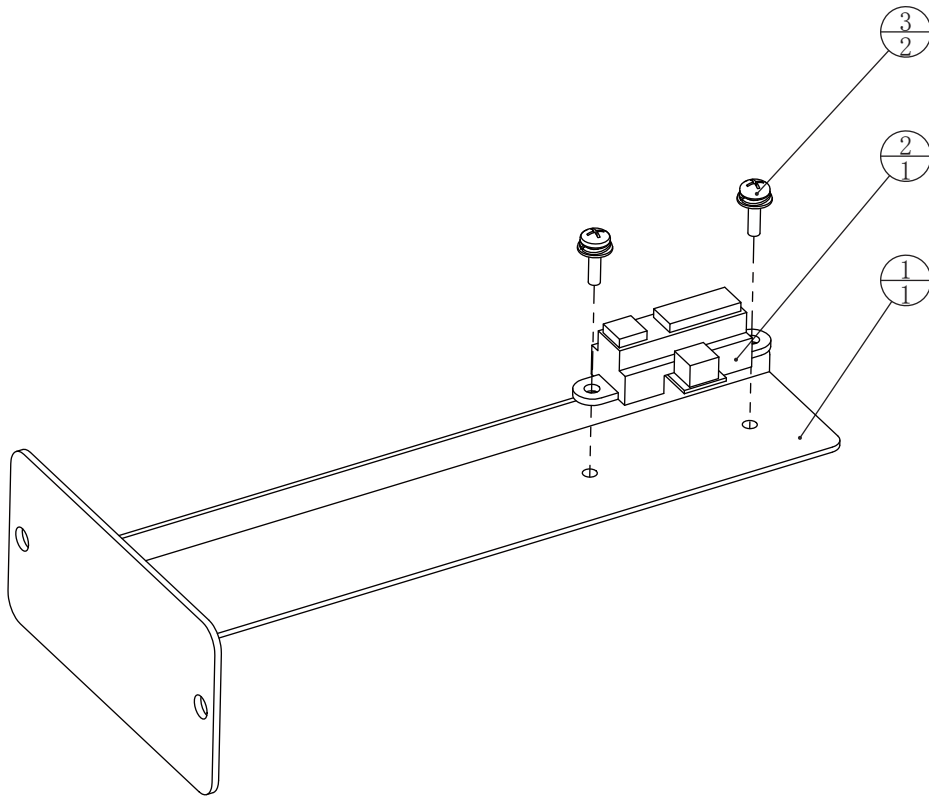

3		Cross recessed fillister head three-combination screw	M3*8 (black)	2	1.6.LS830021
2		Sensor	GP2Y0A41SK0F	1	
1	HXD-0204A01	Sensor fixing rack		1	1.1.IG19G00470
No.	Draw No.	Name	Material/Spec.	Qty.	Product Code

6.4.5 Motor assembly

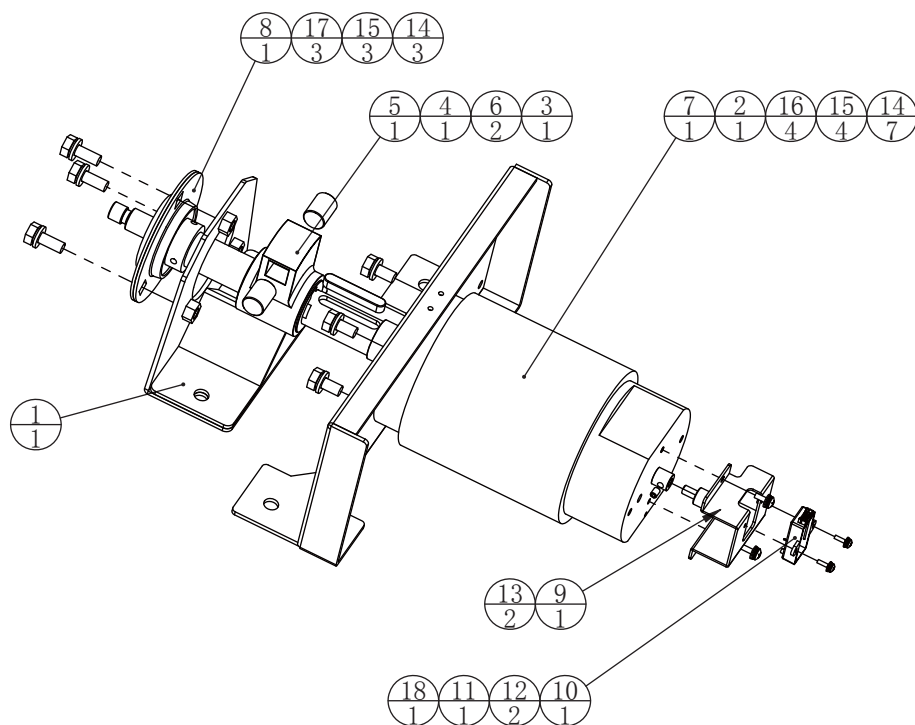

18		Headless hex socket screw	M5*6 (black)	1	1.6.LST50011
17		External hex socket screw	M8*20 (black)	3	1.6.LSM82011
16		External hex socket screw	M8*16 (black)	4	1.6.LSM81021
15		Spring washer	M8 (black)	7	1.6.DP208011
14		Plain washers	φ8*φ16*2.0(black)	7	1.6.DP108011
13		Cross recessed fillister head three-combination screw	M4*8 (black)	2	1.6.LS840021
12		Cross recessed fillister head three-combination screw	M3*8 (black)	2	1.6.LS830021
11		Non contact angle sensor group		1	1.3.IG19003#
10		Non contact angle sensor group		1	1.3.IG19003#
9	HXK-0113A02	Potentiometer fixing plate	SPCC-1.5T	1	1.1.IG19A00410
8		Bearing pedestal	PF205	1	1.4.ZC001010
7		Dc motors	112ZY100-40	1	1.4.MD100022
6	SR1-0501A05	Swing axle pads	Optimal force glue	2	1.1.WA10A00260
5	SR1-0501A04	motor swing axle	45	1	1.4.VR201310
4	SR1-0501A03	Swing axle key	45	1	1.1.WA10A00240
3	SR1-0501A02	motor shaft case	45	1	1.1.WA10A00230
2	SRF-0102A02	motor mounted plate	SPCC-3.0T	1	1.1.WA10E00180
1	SRF-0102A01	motor swing frame support iron	SPCC-3.0T	1	1.1.WA10E00170
No.	Draw No.	Name	Material/Spec.	Qty.	Product Code

6.4.6 Steering wheel light board assembly

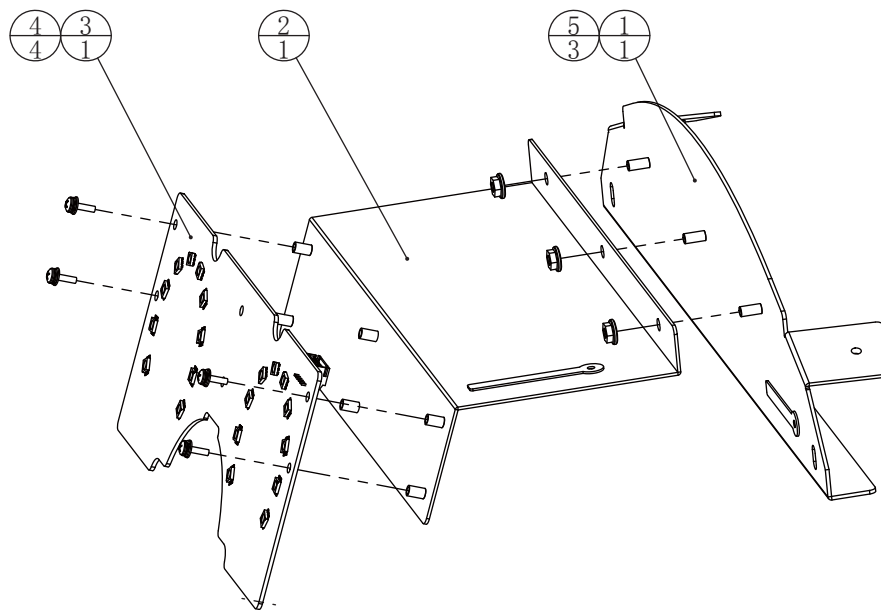

5		Hex head cap screw	M4 (color)	3	1.6.LM204013
4		Cross recessed fillister head three-combination screw	M3*8 (black)	4	1.6.LS830021
3		Led lamp board for dashboard	GK-514-013	1	1.4.IC901850
2	HXD-0206A02	Instrument panel fixing plate two	SPCC-1.5T	1	1.1.IG19G00490
1	HXD-0206A01	Instrument panel fixing plate	SPCC-1.5T	1	1.1.IG19G00480
No.	Draw No.	Name	Material/Spec.	Qty.	Product Code

6.4.7 Bass horn assembly

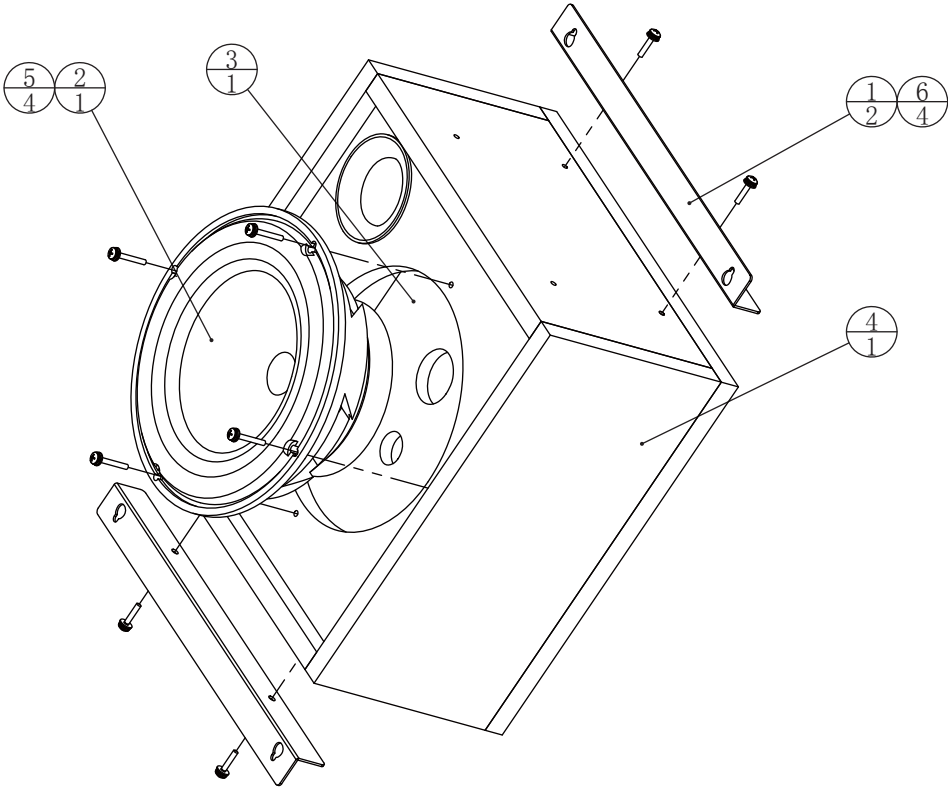

6		Cross recessed fillister head three-combination screw	M4*16 (black)	4	1.6.LS841031
5		Cross recessed fillister head three-combination screw	M4*25 (black)	4	1.6.LS842021
4	HXD-0207B01	Bass speaker	MDF-15.0T	1	1.2.IG19G00060
3		Sponge	20mmf 160mm*400mm	1	1.9.HM030020
2		Woofer	HIT-800W	1	1.5.IG19G00260
1	HXD-0207A01	Heavy bass fixed iron	SECC-1.5T	2	1.1.IG19G00500
No.	Draw No.	Name	Material/Spec.	Qty.	Product Code

6.4.8 Right console speaker assembly

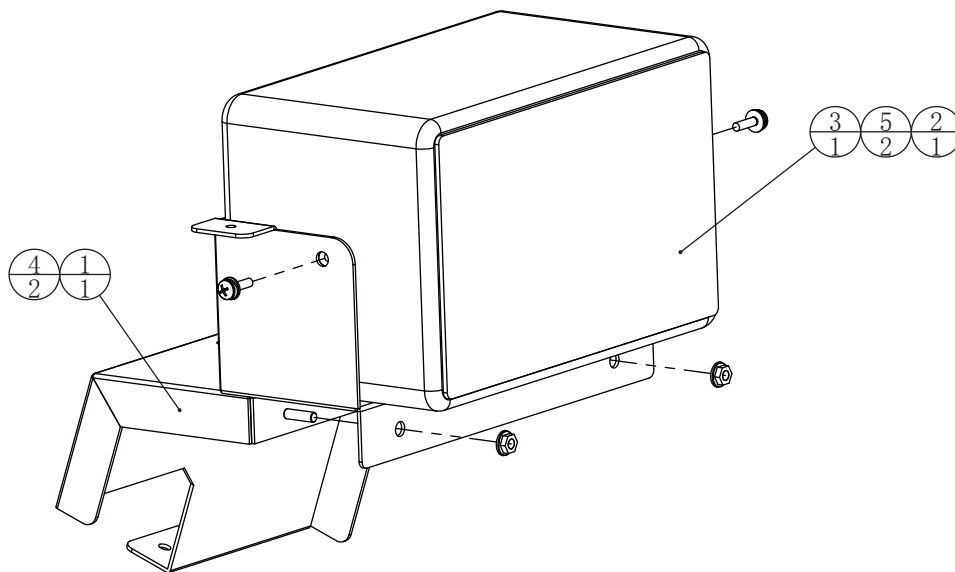

5		Cross recessed fillister head three-combination screw	M4*12 (black)	2	1.6.LS841021
4		Hex head cap screw	M4 (color)	2	1.6.LM204013
3		Loudspeaker 4"	4" 4Ω 25W(JK-BX-	1	1.4.YSD00010
2	HXD-0208A02	Console speaker two	SPCC-1.5T	1	1.1.IG19G00520
1	HXD-0208A01	Console speaker one	SPCC-1.5T	1	1.1.IG19G00510
No.	Draw No.	Name	Material/Spec.	Qty.	Product Code

6.4.9 Left console speaker assembly

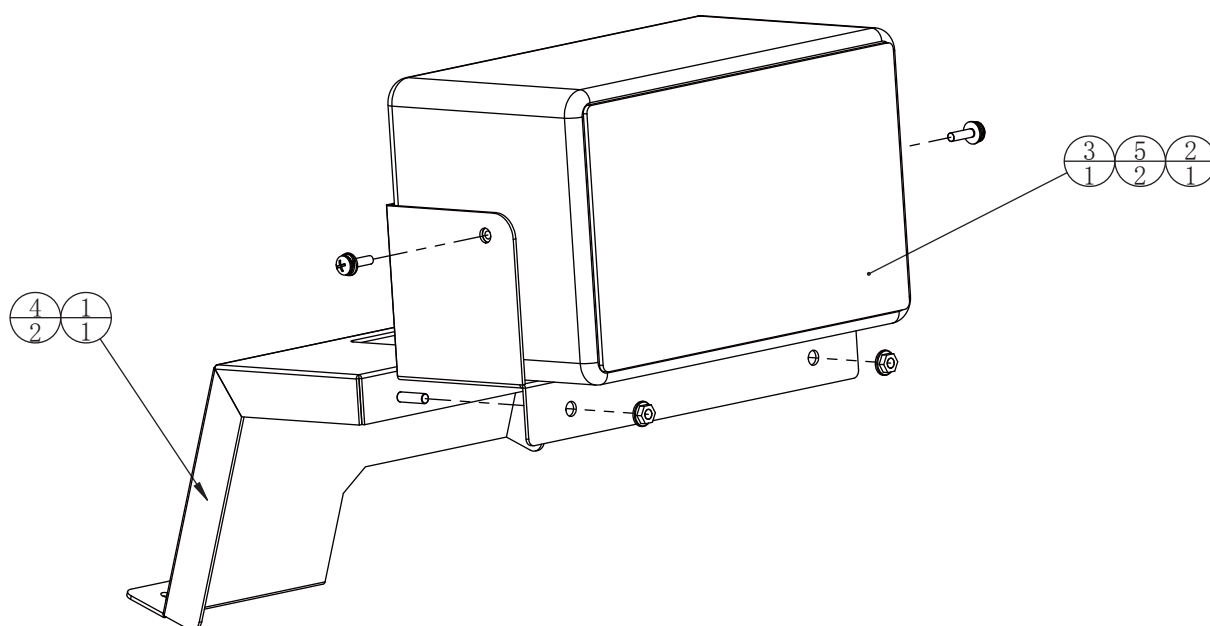

5		Cross recessed fillister head three-combination screw	M4*12 (black)	2	1.6.LS841021
4		Hex head cap screw	M4 (color)	2	1.6.LM204013
3		Loudspeaker 4"	4" 4Ω 25W(JK-BX)	1	1.4.YSD00010
2	HXD-0209A02	Console speaker four	SPCC-1.5T	1	1.1.IG19G00540
1	HXD-0209A01	Console speaker three	SPCC-1.5T	1	1.1.IG19G00530
No.	Draw No.	Name	Material/Spec.	Qty.	Product Code

6.4.10 I/O board assembly

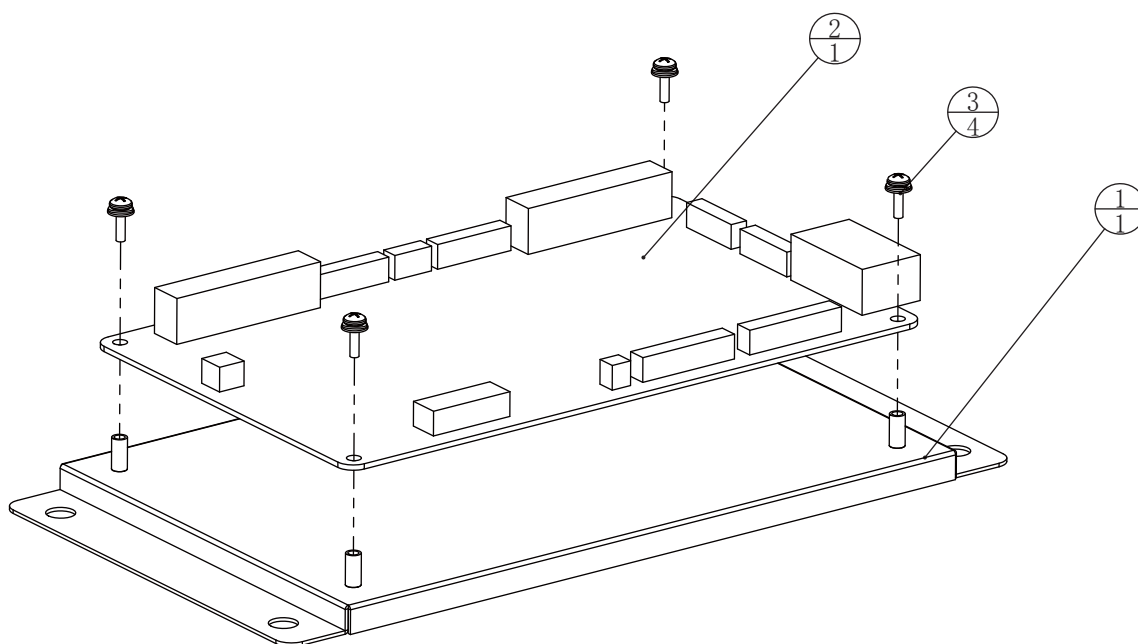

3		Cross recessed fillister head three-combination screw	M3*8 (chrome)	4	1.6.LS830022
2		I/O control panel	LQ_1088-01	1	1.3.IG19001#
1	HXD-0210A01	I/O board seat	SECC-1.0T	1	1.1.IG19G00550
No.	Draw No.	Name	Material/Spec.	Qty.	Product Code

6.4.11 Motor control board assembly

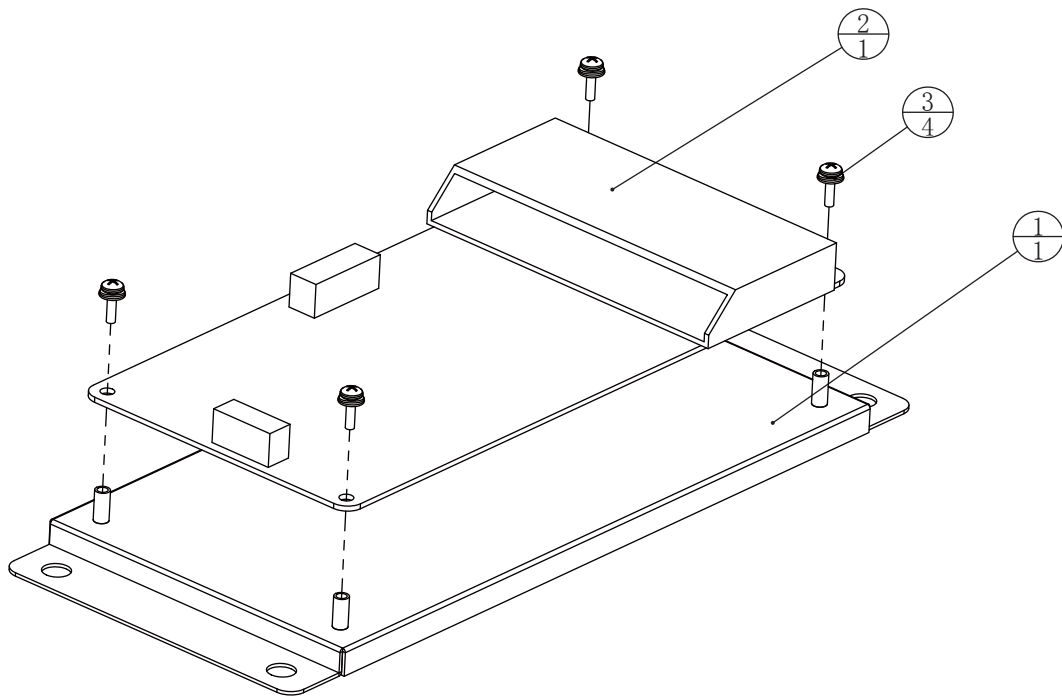

3		Cross recessed fillister head three-combination screw	M3*8 (chrome)	4	1.6.LS830022
2		Motor control panel	LQ-A_1094-00	1	1.1.IG19G00560
1	HXD-0211A01	Motor control panel	SECC-1.0T	1	
No.	Draw No.	Name	Material/Spec.	Qty.	Product Code

6.4.12 Air compressor control board assembly

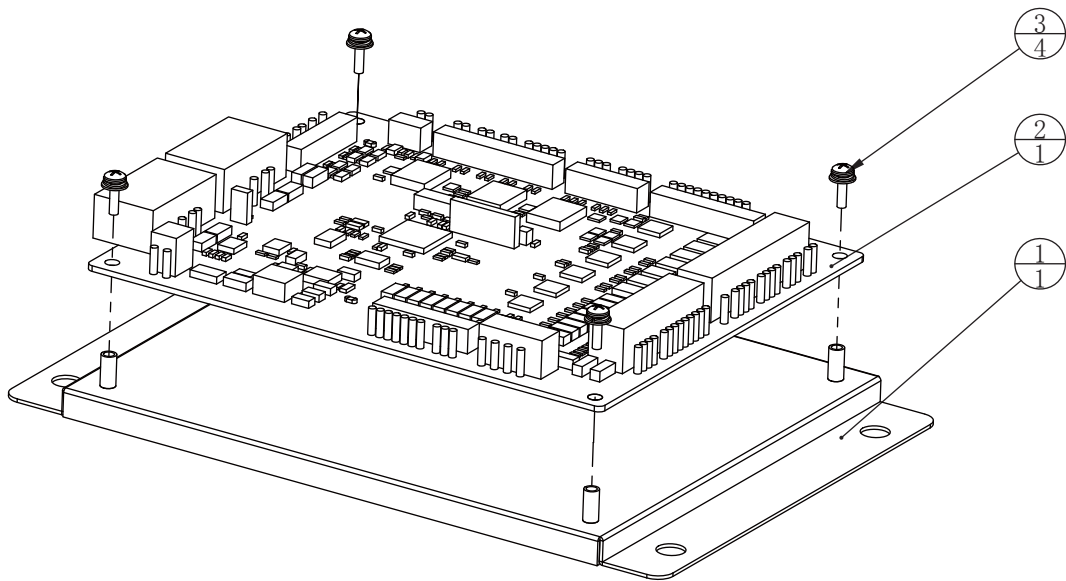

3		Cross recessed fillister head three-combination screw	M3*8 (chrome)	4	1.6.LS830022
2		Air pressure system control panel		1	1.3.IG19G00010#
1	HXD-0212A01	Fixed seat for air clamp plate	SECC-1.0T	1	1.1.IG19G00570
No.	Draw No.	Name	Material/Spec.	Qty.	Product Code

6.4.13 Control panel assembly

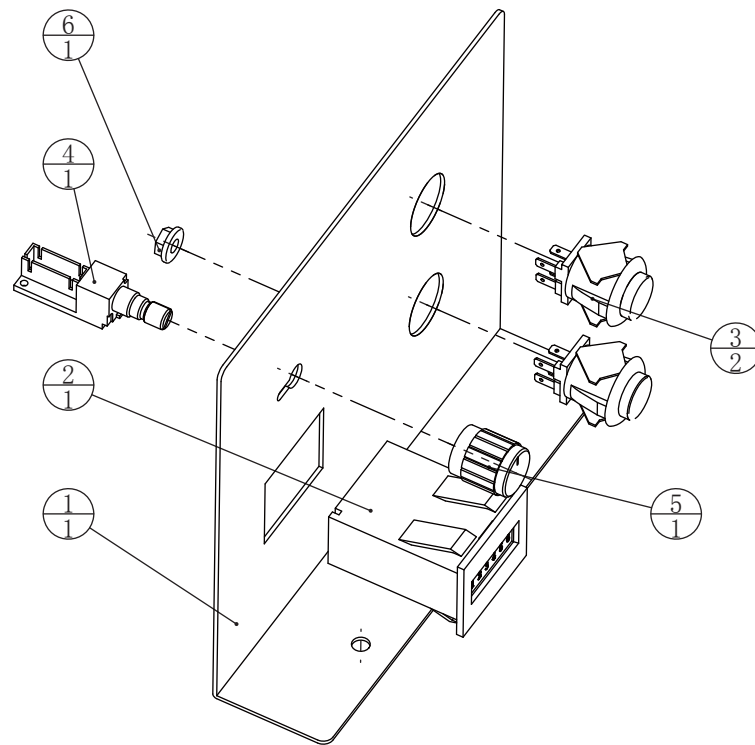

6		Hex head cap screw	M4 (color)	1	1.6.LM204013
5		Potentiometer knob	Φ13mm	1	1.4.VR201310
4		Volume vr components	VR-B10KΩ	1	1.4.VR160010
3		Round button	SDP-103C-22RB	2	1.4.AJ500012#
2		Counter	DC 12V	1	1.4.JS100020
1	HXD-0213A01	Control panel	SPCC-1.2T	1	1.1.IG19G00580
No.	Draw No.	Name	Material/Spec.	Qty.	Product Code

6.5 Seat assembly

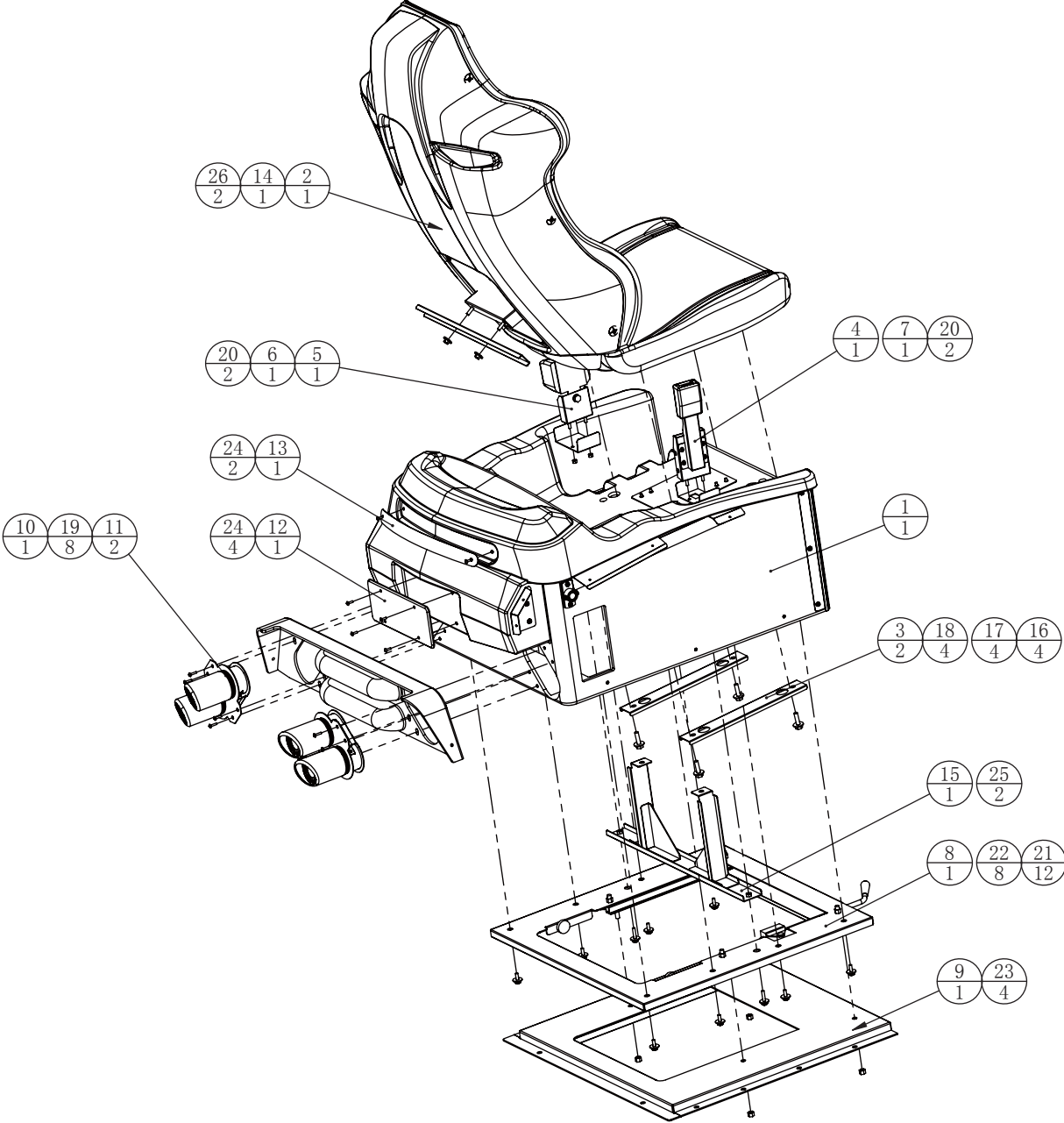

26		Self-Locking Nuts	M6 (Galvanization)	2	1.6.LM306014
25		Cross recessed fillister head three-combination screw	M6*25 (black)	2	1.6.LS862021
24		Hex socket cap screws	M4*12 (black)	6	1.6.LS141021
23		Self-Locking Nuts	M8 (Galvanization)	4	1.6.LM308014
22		Cross recessed fillister head three-combination screw	M6*16 (black)	8	1.6.LS861031
21		Plain washers	Φ6*Φ20*2.0(black)	12	1.6.DP106061
20		Self-Locking Nuts	M5 (Galvanization)	4	1.6.LM305014
19		Hex socket cap screws	M4*16 (chrome)	8	1.6.LS141032
18		External hex socket screw	M8*30 (black)	4	1.6.LSM83011
17		Spring washer	M8 (black)	4	1.6.DP208011
16		Plain washers	φ8*φ22*2.0(black)	4	1.6.DP108031
15	HXD-0300A06	Rotational support		1	1.1.IG19G00640
14	HXD-0300A05	Fixed plate	SPCC-1.5T	1	1.1.IG19G00630
13	HXD-P0011	Brake lamp panel	PVC-1.0T	1	1.7.IG19G00120
12	HXD-P0007	Acrylic plate	PMMA-5.0T	1	1.7.IG19G00080
11	HXD-0306000	Exhaust pipe assembly		2	
10	HXD-0300C01	Seat tail blister	ABS-5.0T	1	1.8.IG19G010
9	HXD-0300A04	Slide under the seat		1	1.1.IG19G00620
8	HXD-0305000	Slide rail assembly		1	
7	HXD-0300A03	Safety belt reinforced metal two	SECC-1.5T	1	1.1.IG19G00610
6	HXD-0300A02	Safety belt reinforced metal one	SECC-1.5T	1	1.1.IG19G00600
5	HXD-0304000	Seat belt assembly		1	
4	HXD-0303000	Safety belt buckle assembly		1	
3	HXD-0300A01	Chair reinforced metal	SECC-1.5T	2	1.1.IG19G00590
2	HXD-0302000	Seat back assembly		1	
1	HXD-0301000	Seat plastic assembly		1	
No.	Draw No.	Name	Material/Spec.	Qty.	Product Code

6.5.1 Seat plastic assembly

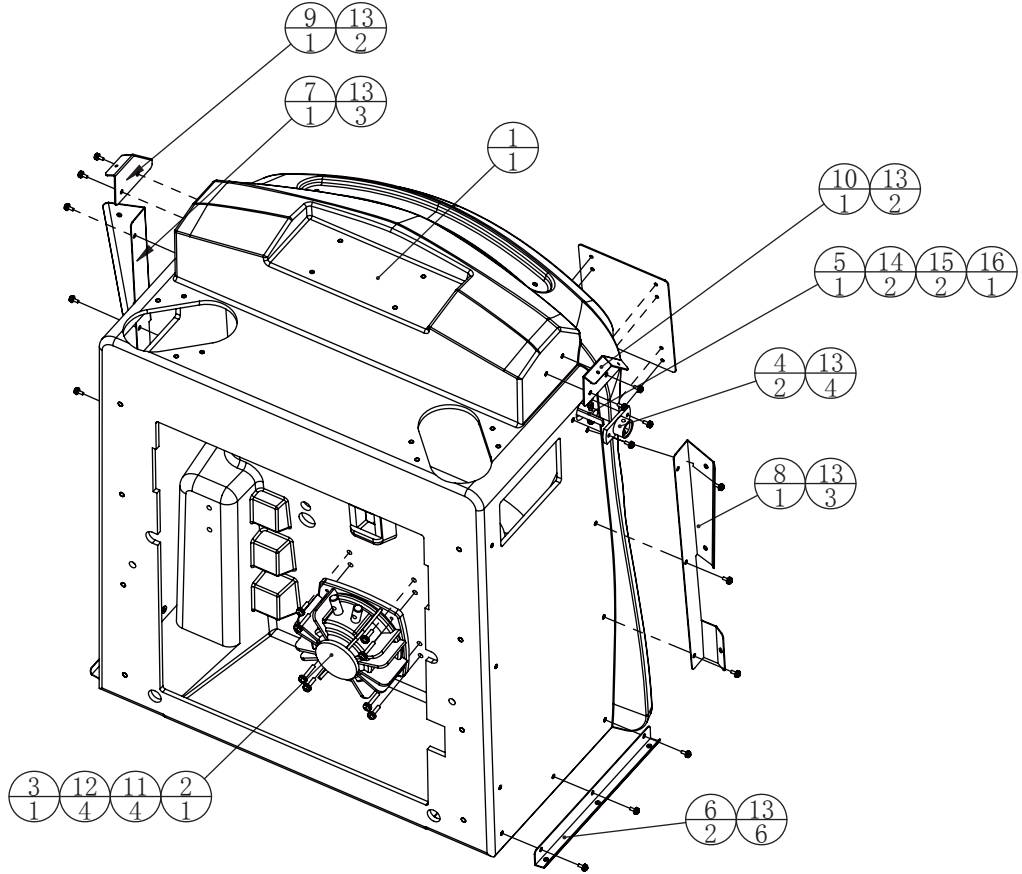

16		5050 strip light	DC12V RGB60 L=1600mm	1	1.4.ZM9E0A30
15		Self-Locking Nuts	M4 (Galvanization)	2	1.6.LM304014
14		Cross recessed fillister head three-combination screw	M4*30 (black)	2	1.6.LS843011
13		Cross recessed fillister head three-combination screw	M4*8 (black)	20	1.6.LS840021
12		Cross recessed fillister head three-combination screw	M5*25 (chrome)	4	1.6.LS852022
11		Cross recessed fillister head three-combination screw	M5*16 (chrome)	4	1.6.LS851032
10	HXD-0301A06	Side cover plastic fixed hardware six	SECC-1.5T	1	1.1.IG19G00700
9	HXD-0301A05	Side cover plastic fixed hardware five	SECC-1.5T	1	1.1.IG19G00690
8	HXD-0301A04	Side cover plastic fixed hardware four	SECC-1.0T	1	1.1.IG19G00680
7	HXD-0301A03	fixed hardware three	SECC-1.0T	1	1.1.IG19G00670
6	HXD-0301A02	fixed hardware two	SECC-1.0T	2	1.1.IG19G00660
5	HXD-0301C03	Side cover plastic fixed Lamp bar	white POM	1	1.8.IG19G040
4	HXD-0301C02	Lamp support seat	white POM	2	1.8.IG19G030
3	HXD-0301A01	Horn fixing plate	SECC-1.5T	1	1.1.IG19G00650
2		4Ω/50W	Low frequency vibrator	1	1.4.YSA00010
1	HXD-0301C01	Plastic seat	LDPE-7.0T	1	1.8.IG19G020
No.	Draw No.	Name	Material/Spec.	Qty.	Product Code

6.5.2 Seat back assembly

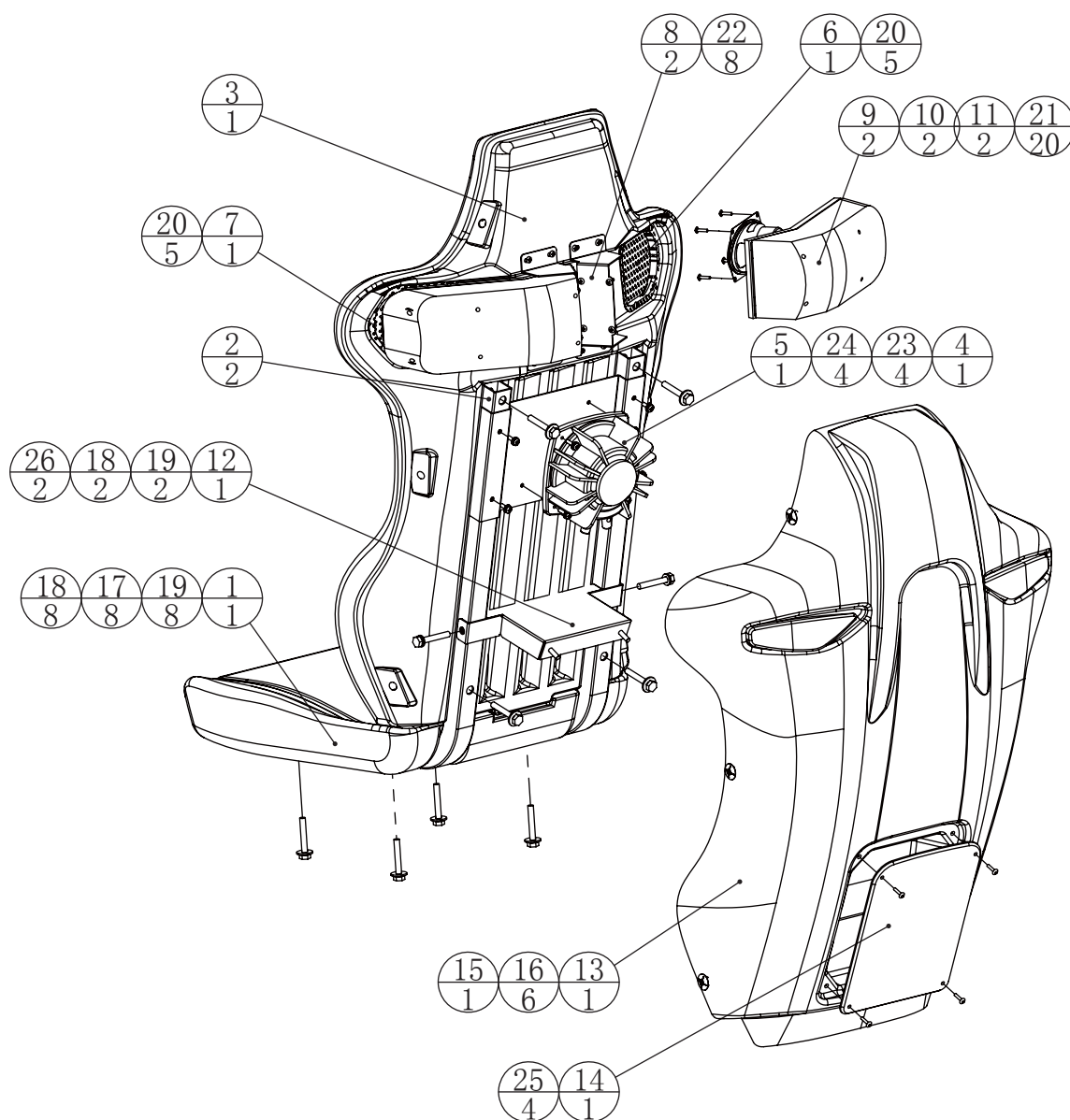

26		Plain washers	φ8*φ16*2.0 (black)	2	1.6.DP108011
25		Hex socket cap screws	M4*16 (black)	4	1.6.LS141031
24		Cross recessed fillister head three-combination screw	M5*16 (black)	4	1.6.LS851031
23		Cross recessed fillister head three-combination screw	M5*12 (black)	4	1.6.LS851021
22		Cross the big flat head screw	M4*12 (black)	8	1.6.LS241021
21		Cross the big flat head self-drilling screw	M4*16 (black)	20	1.6.LS341041
20		Cross the big flat head self-drilling screw	M4*8 (chrome)	10	1.6.LS340012
19		External hex socket screw	M8*50 (black)	10	1.6.LSM85011
18		Spring washer	M8 (black)	10	1.6.DP208011
17		Plain washers	φ8*φ22*2.0 (black)	8	1.6.DP108031
16		Plastic screw		6	1.6.LSY82050
15		turn signal lamp (without control box)	R-100/DC12V	1	1.4.ZM9H0010
14	HXD-P0008	ACRYLIC CHAIR	PMMA-5.0T	1	1.7.IG19G00090
13	HXD-0302C01	Seat back cover	ABS-4.0T	1	1.8.IG19G0050
12	HXD-0302A02	Seat back support		1	1.1.IG19G00720
11		Ellipse antimagnetic speaker	3x5 8Ω 15W	2	1.4.YS300010
10		Seat horn cap		2	1.8.IG040330
9		Seat horn hood		2	1.8.IG040320
8	6100	mounted base for ellipse speaker of seat		2	1.1.IG040700
7		seat speaker cover r	1.0T	1	1.1.IG041001
6		seat speaker cover l	1.0T	1	1.1.IG041000
5		Low frequency vibrator	4Ω/50W	1	1.4.YSA00010
4	HXK-0501A01	mounted plate for vibrator of seat	SPCC-1.5T	1	1.1.IG19A00660
3	SD3-07-01-03	Rear lamp cover plate		1	1.8.IG04A080
2	HXD-0302A01	Seat elbow	30*2/Q235	2	1.1.IG19G00710
1	HXK-0501C01	The exhaust pipe cover		1	1.8.IG19A080
No.	Draw No.	Name	Material/Spec.	Qty.	Product Code

6.5.3 Safety belt buckle assembly

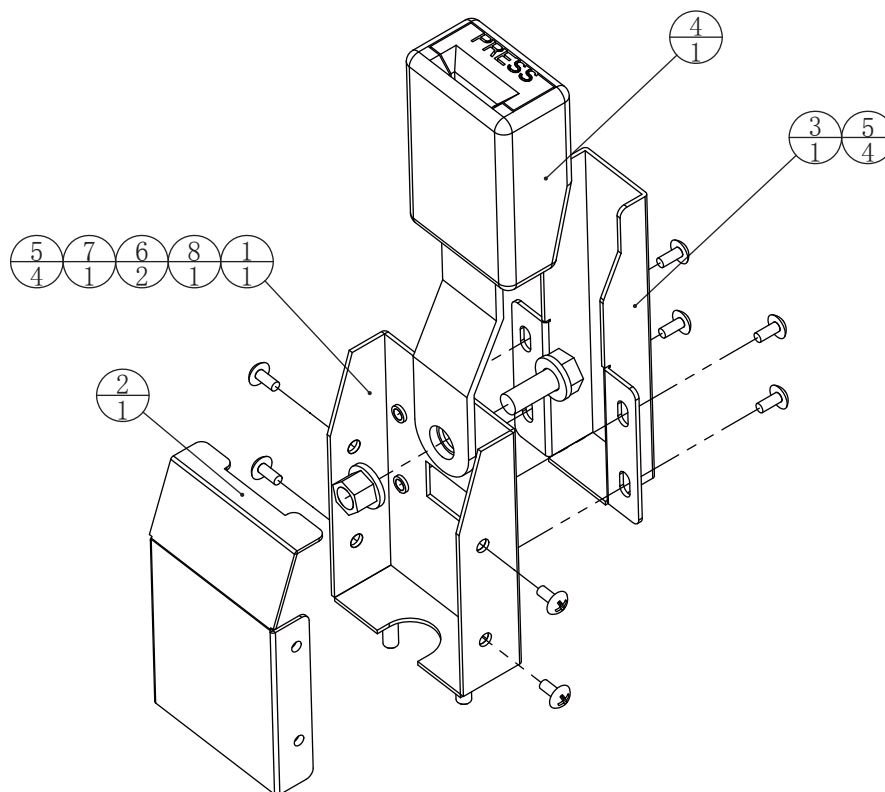

8		Self-Locking Nuts	M8 (Galvanization)	1	1.6.LM308014
7		External hex socket screw	M8*20 (black)	1	1.6.LSM82011
6		Plain washers	φ8*φ16*2.0 (black)	2	1.6.DP108011
5		Cross the big flat head screw	M4*8 (black)	8	1.6.LS240021
4		Safety belt		1	1.4.AQ000020
3	SRH-0302A02	Seat belt cover a	SPCC-1.5T	1	1.1.WA16C00870
2	HXD-0303A02	Safety belt fixing seat two	SPCC-1.2T	1	1.1.IG19G00740
1	HXD-0303A01	Safety belt fixing seat	SPCC-1.5T	1	1.1.IG19G00730
No.	Draw No.	Name	Material/Spec.	Qty.	Product Code

6.5.4 Seat belt assembly

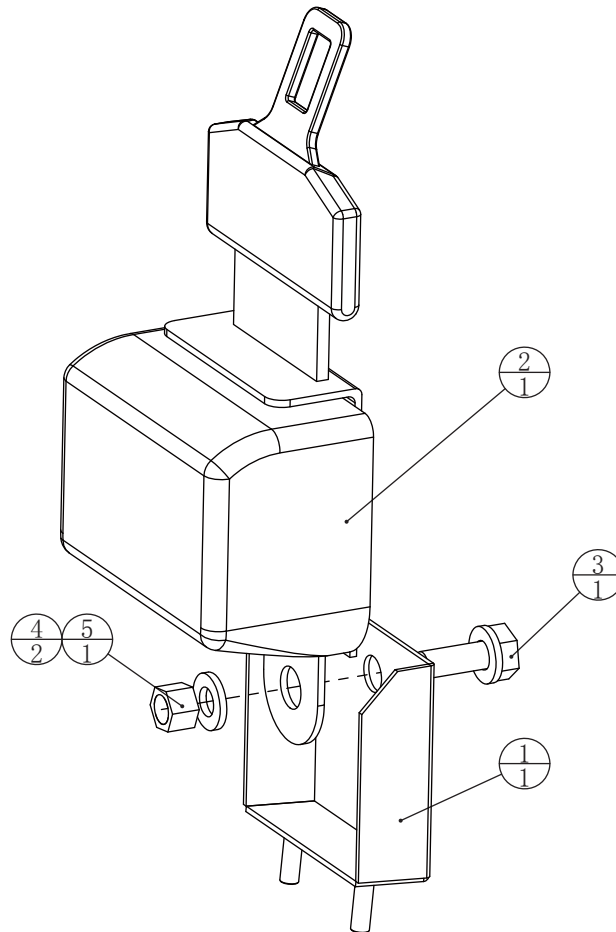

5		Self-Locking Nuts	M8 (Galvanization)	1	1.6.LM308014
4		Plain washers	$\varnothing 8 \times \varphi 16 \times 2.0$ (black)	2	1.6.DP108011
3		External hex socket screw	M8*20 (black)	1	1.6.LSM82011
2		Safety belt		1	1.4.AQ000020
1	HXD-0304A01	Safety belt fixing seat three	SPCC-1.5T	1	1.1.IG19G00750
No.	Draw No.	Name	Material/Spec.	Qty.	Product Code

6.5.5 Slide rail assembly

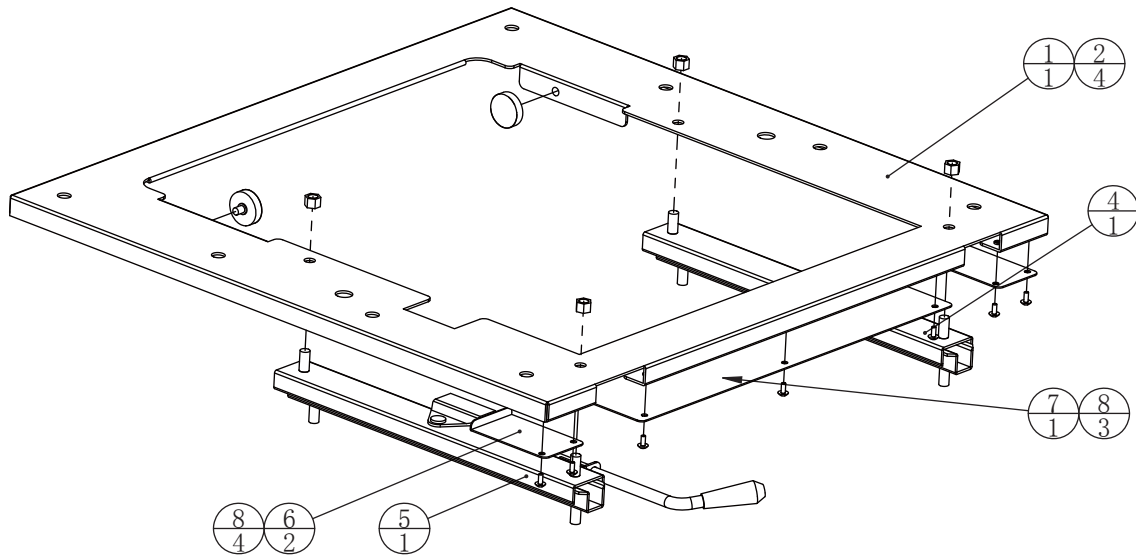

8		Cross the big flat head screw	M4*8 (black)	7	1.6.LS240021
7	HXD-0305A03	Hardware cover plate two	SPCC-1.0T	1	1.1.IG19G00780
6	HXD-0305A02	Hardware cover plate	SPCC-1.0T	2	1.1.IG19G00770
5		Sliding rail r		1	1.1.AA030101
4		Sliding rail l		1	1.1.AA030100
3		Movable pulley	DR-28-B0.5	2	1.4.HL010010
2		Self-Locking Nuts	M8 (Galvanization)	4	1.6.LM308014
1	HXD-0305A01	Rail seat	SPCC-2.0T	1	1.1.IG19G00760
No.	Draw No.	Name	Material/Spec.	Qty.	Product Code

6.5.6 Exhaust pipe assembly

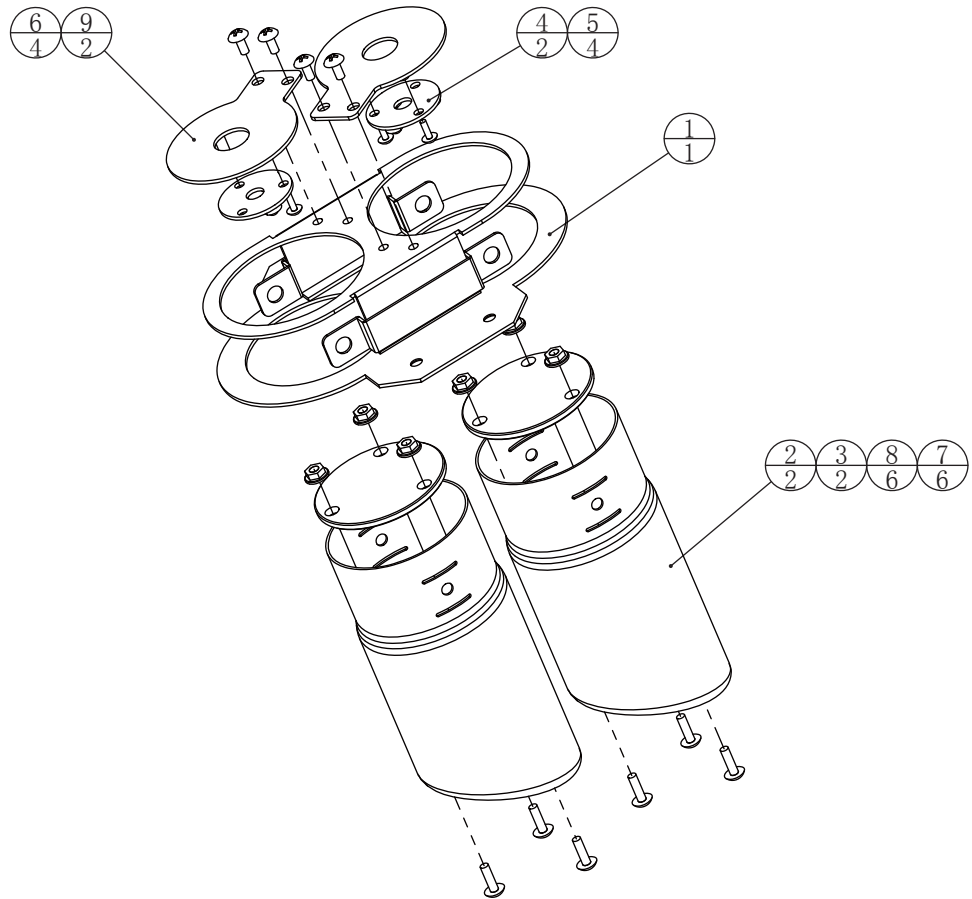

9	HXD-0306A02	The exhaust tube plate fixed plate	SECC-1.5T	2	1.1.IG19G00800
8		Hex head cap screw	M4 (color)	6	1.6.LM204013
7		Hex socket cap screws	M4*12 (chrome)	6	1.6.LS141022
6		Cross the big flat head screw	M4*8 (black)	4	1.6.LS240021
5		Cross the big flat head screw	M3*8 (black)	4	1.6.LS230081
4		Round pcb with led	DC12V	2	1.4.ZM9G0010
3	HXK-0204D01	Exhaust pipe decorative acrylic	PMMA-3.0T	2	1.7.IG19A00050
2		Exhaust pipe		2	1.4.JG09C010
1	HXD-0306A01	Exhaust pipe support		1	1.1.IG19G00790
No.	Draw No.	Name	Material/Spec.	Qty.	Product Code

6.6 Left seat cover assembly

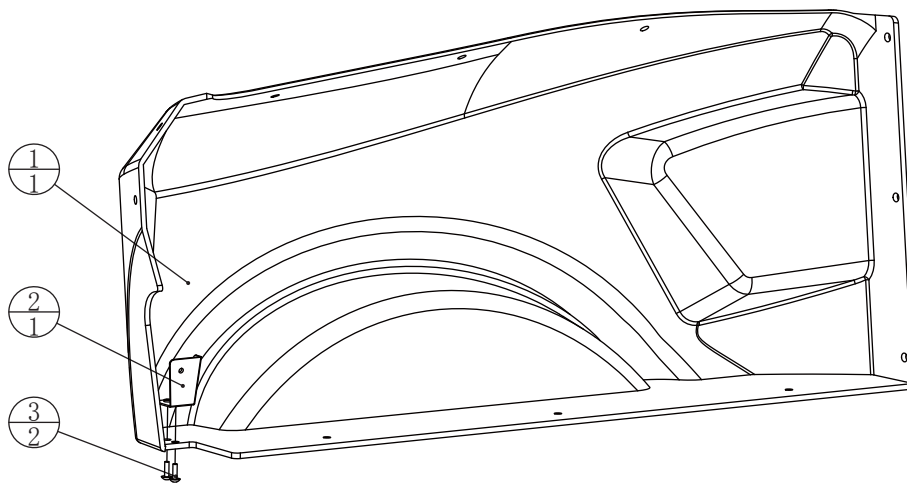

3		Hex socket cap screws	M4*12 (black)	2	1.6.LS141021
2	HXD-0400A01	Side cover plastic fixed hardware seven	SECC-1.0T	1	1.1.IG19G00810
1	HXD-0400C01	Seat side cover I	ABS-4.5T	1	1.8.IG19G060
No.	Draw No.	Name	Material/Spec.	Qty.	Product Code

6.7 Right seat cover assembly

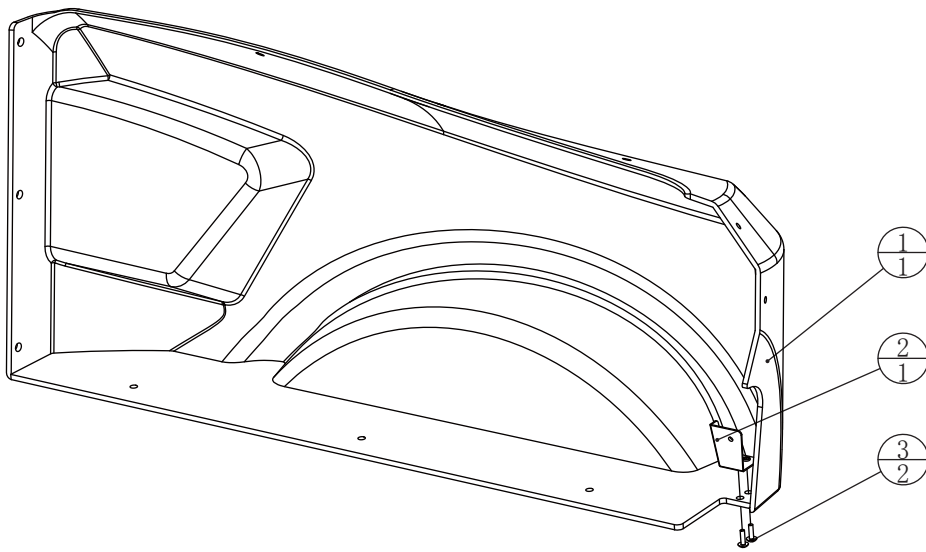

3		Hex socket cap screws	M4*12 (black)	2	1.6.LS141021
2	HXD-0500A01	Side cover plastic fixed hardware eight	SECC-1.0T	1	1.1.IG19G00820
1	HXD-0500C01	Seat side cover r	ABS-4.5T	1	1.8.IG19G070
No.	Draw No.	Name	Material/Spec.	Qty.	Product Code

6.8 Light box assembly

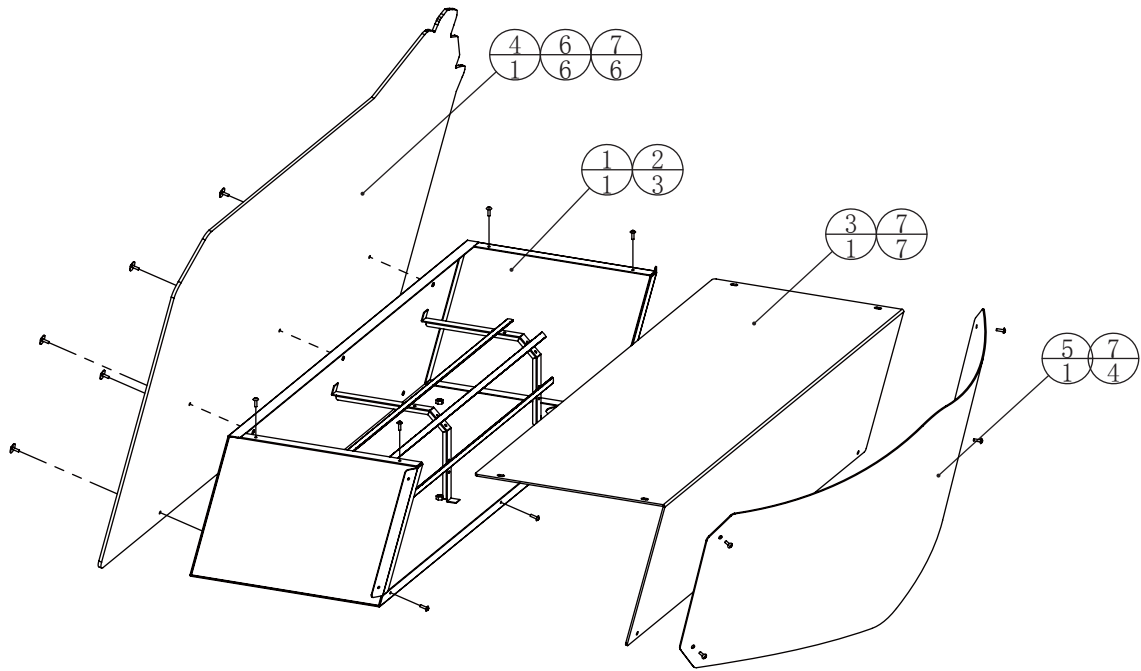

7		Hex socket cap screws	M4*12 (black)	17	1.6.LS141021
6		Plain washers	Φ4*Φ16*1.0(black)	6	1.6.DP104041
5	HXD-P0005	Decorative board	PVC-2.0T	1	1.7.IG19G00060
4	HXD-P0004	Background trim panel	Andy board-5.0T	1	1.7.IG19G00050
3	HXD-0600D01	Signboard lamp box acrylic	PMMA-3.0T	1	1.7.IG19G00020
2		5050 hard light	DC12V 75 L=800mm	3	1.4.ZM9E1079
1	HXD-0600A01	Box frame		1	1.1.IG19G00830
No.	Draw No.	Name	Material/Spec.	Qty.	Product Code

6.9 Rear access door assembly

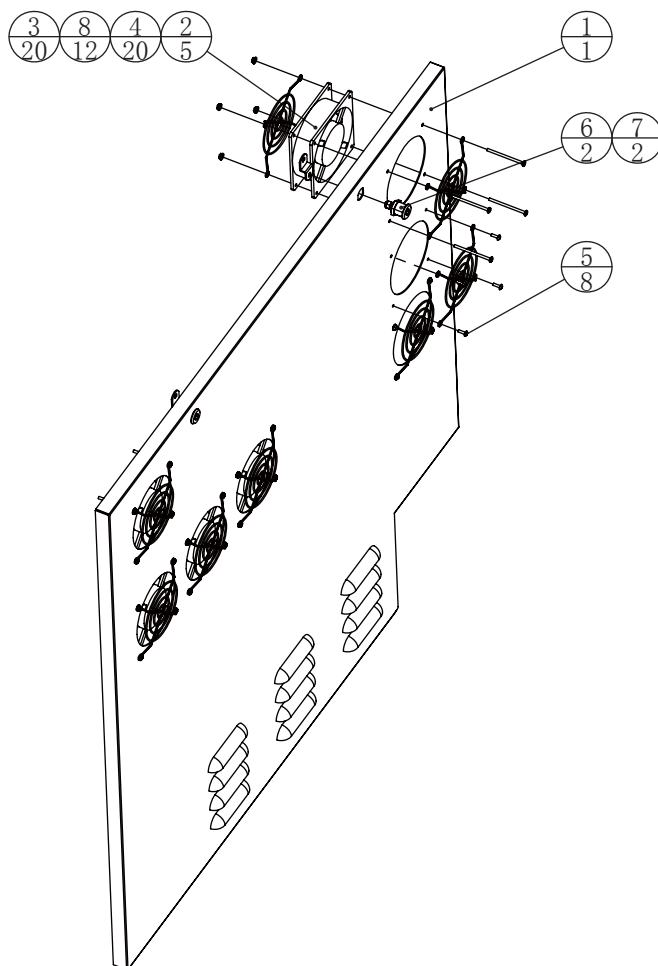

8		Fan cover	120*120	12	1.4.FS300020
7		Locking plate	(002)	2	1.4.SJ500050
6		Lock	5555key-S	2	1.4.SJ120130
5		Cross the big flat head screw	M4*12 (black)	8	1.6.LS241021
4		Hex head cap screw	M4 (color)	20	1.6.LM204013
3		Cross recessed cheese head screws	M4*60 (black)	20	1.6.LS746011
2		Fan with bearing	120*120/AC110V	5	
1	HXD-0700A01	Screen maintenance door		1	1.1.IG19G00840
No.	Draw No.	Name	Material/Spec.	Qty.	Product Code

6.10 Console assembly

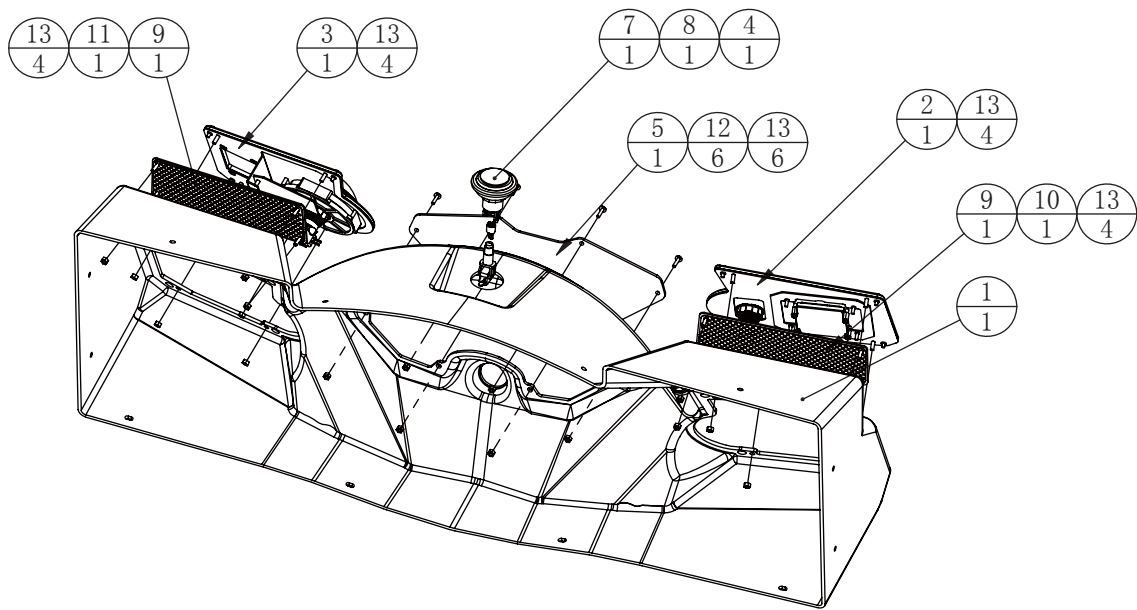

13		Self-Locking Nuts	M4 (Galvanization)	22	1.6.LM304014
12		Hex socket cap screws	M4*16 (black)	6	1.6.LS141031
11	HXK-0110A03	speaker cover of control panel - l	SPCC-2.0T	1	1.1.IG19A00330
10	HXK-0110A02	speaker cover of control panel - r	SPCC-2.0T	1	1.1.IG19A00320
9	HXK-0110A01	speaker cover of control panel	0.8T	2	1.1.IG19A00310
8		Led lamp for button	12V white (T103W-	1	1.4.AJA01040
7		Round push button with lamp	Φ44 whiteBLC-TNBK-B-CW	1	1.4.AJ104011#
6	HXD-0800D01	Emergency stop button acrylic	PMMA-5.0T	1	1.7.IG19G00030
5	HXK-P0010	Dashboard acrylic	PMMA-5.0T	1	1.7.IG19A00170
4		Micro switch	3P MN3-0300DB	1	1.4.SW103010
3	HXD-0802000	Keypad assembly		1	
2	HXD-0801000E	Number button assembly		1	
1	HXD-0800C01	The front cover	ABS-4.0T	1	1.8.IG19G080
No.	Draw No.	Name	Material/Spec.	Qty.	Product Code

6.10.1 Number button assembly

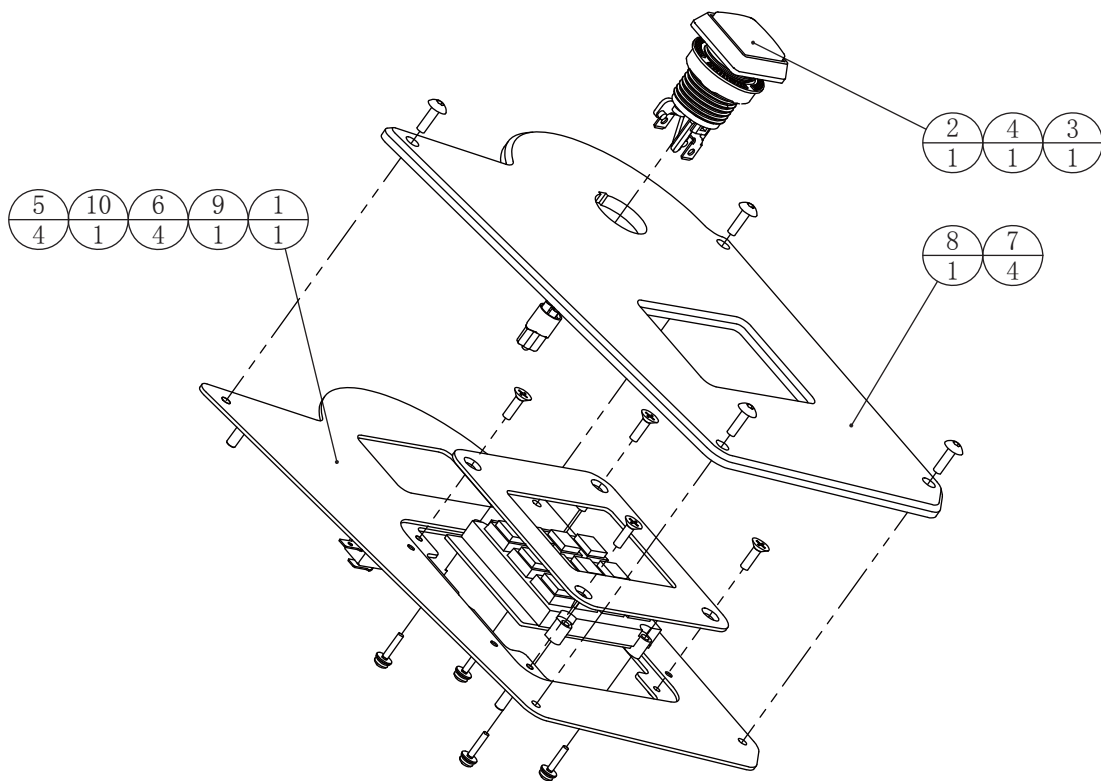

10		Number button	IP65 ROHS	1	1.4.AJD02300
9	HXK-0110A06	Digital key fixing plate	SPCC-1.5T	1	1.1.IG19B00010
8	HXK-P0008E	Switch keyboard acrylic	PMMA-5.0T	1	1.7.IG19B00150
7		Hex socket cap screws	M4*12(black)	4	1.6.LS141021
6		Cross recessed countersunk head screws	M4*12 (black)	4	1.6.LS41021
5		Cross recessed fillister head three-combination screw	M3*12 (black)	4	1.6.LS841021
4		Led lamp for button	12V white (T103W-12V-SMD)	1	1.4.AJA01040
3		Micro switch	3P MN3-0300DB	1	1.4.SW103010
2		Square button	BLC-DP-BK-E-CB	1	1.4.AJ606053
1	HXK-0110A05	Left side positioning board of control table		1	1.1.IG19A00350
No.	Draw No.	Name	Material/Spec.	Qty.	Product Code

6.10.2 Keypad assembly

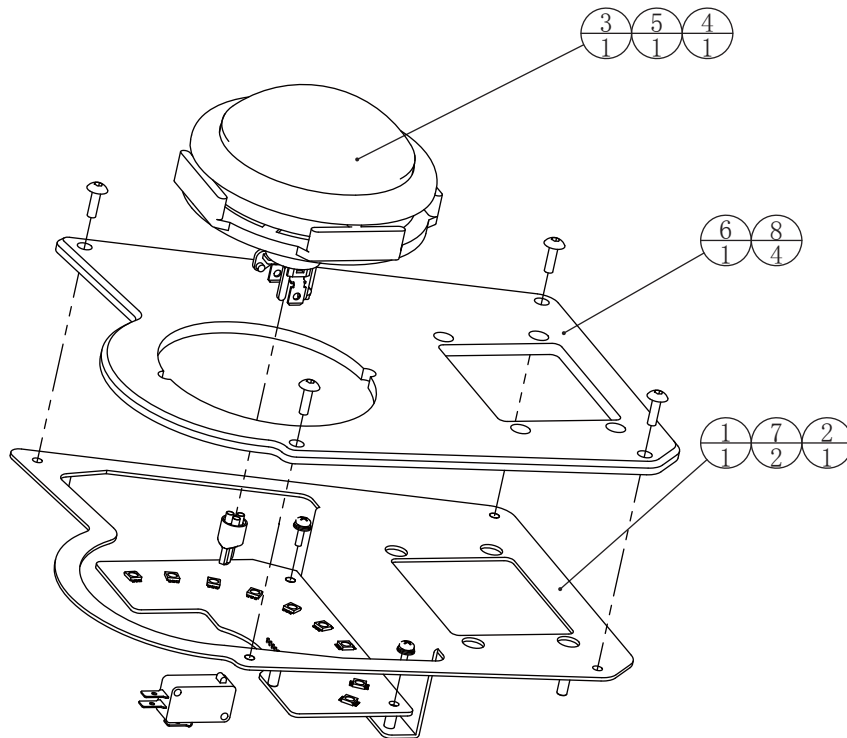

8		Hex socket cap screws	M4*12 (black)	4	1.6.LS141021
7		Cross recessed fillister head three-combination screw	M3*8 (black)	2	1.6.LS830021
6	HXK-P0009	Shift lever acrylic	PMMA-5.0T	1	1.7.IG19A00160
5		Led lamp for button	12V white (T103W-12V-SMD)	1	1.4.AJA01040
4		Micro switch	3P MN3-0300DB	1	1.4.SW103010
3		Round button	∅100-DOME-CW	1	1.4.AJ320011
2		Led lamp board for button	GK-514-011	1	1.4.IC901860
1	HXK-0110A07	Start button fixed sheet metal	SPCC-1.5T	1	1.1.IG19A00370
No.	Draw No.	Name	Material/Spec.	Qty.	Product Code

7. Printing Pattern

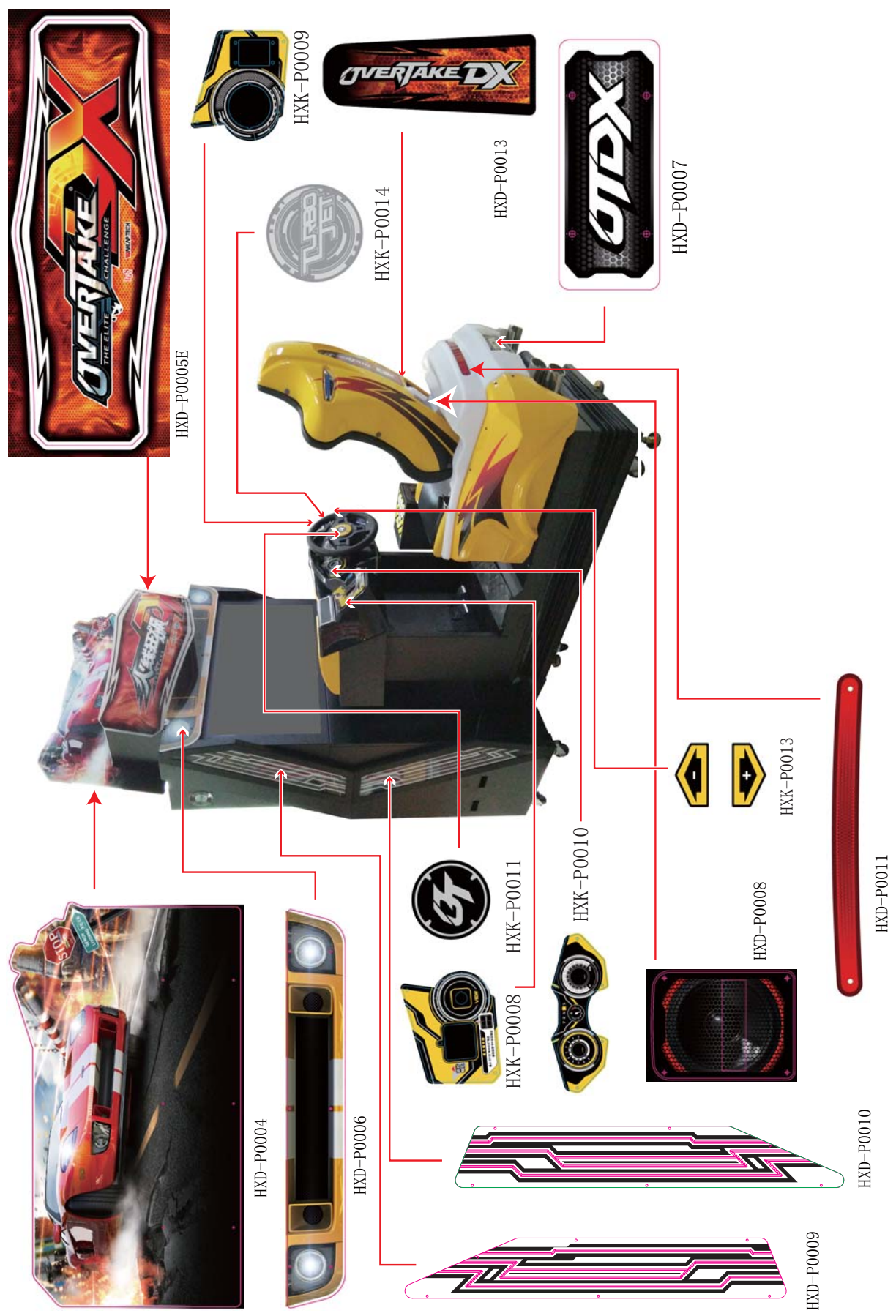

8. Wiring Diagram

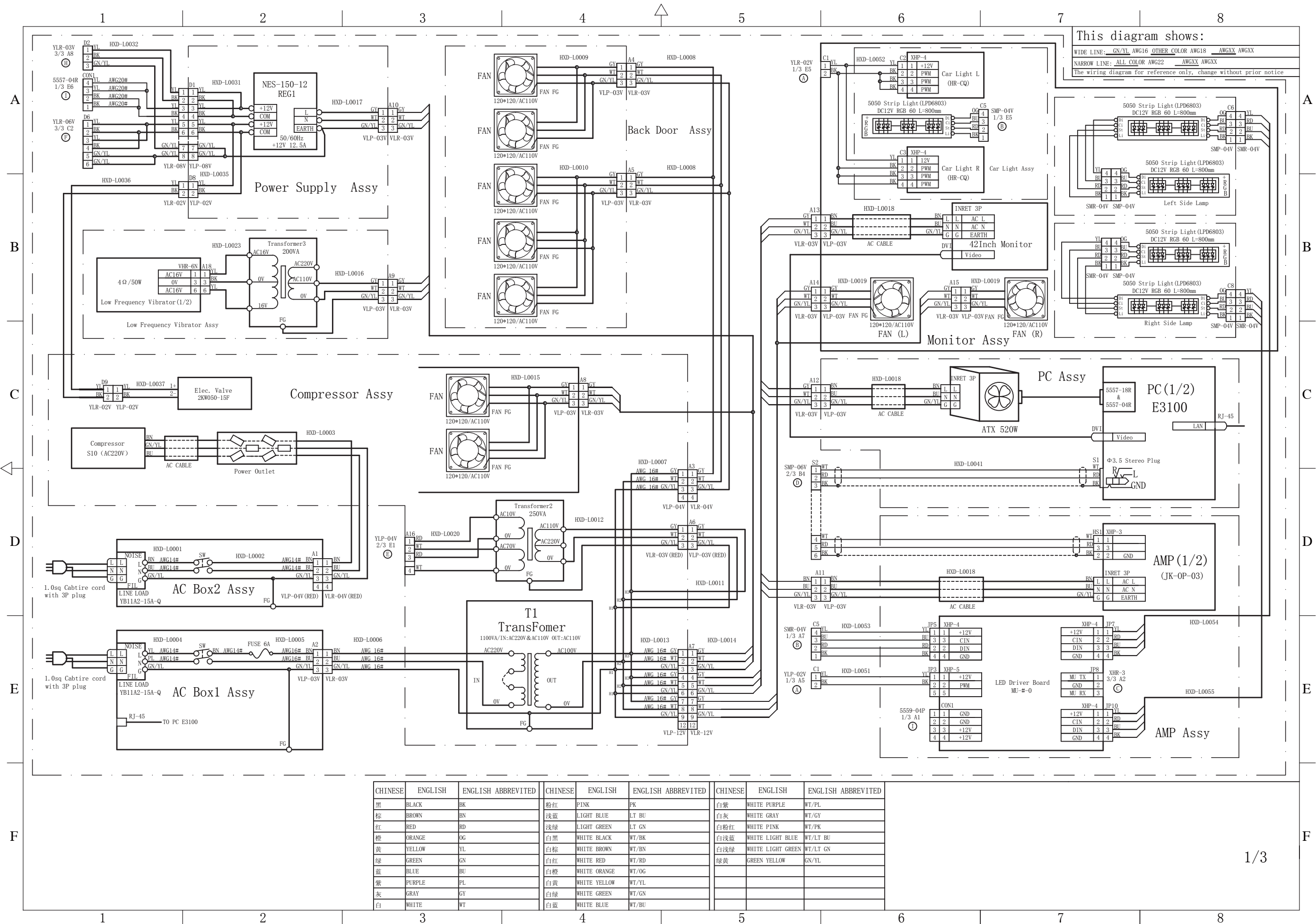

This diagram shows:
 WIDE LINE: GN/YL AWG16 OTHER COLOR AWG18 AWGXX AWGXX
 NARROW LINE: ALL COLOR AWG22 AWGXX AWGXX
 The wiring diagram for reference only, change without prior notice

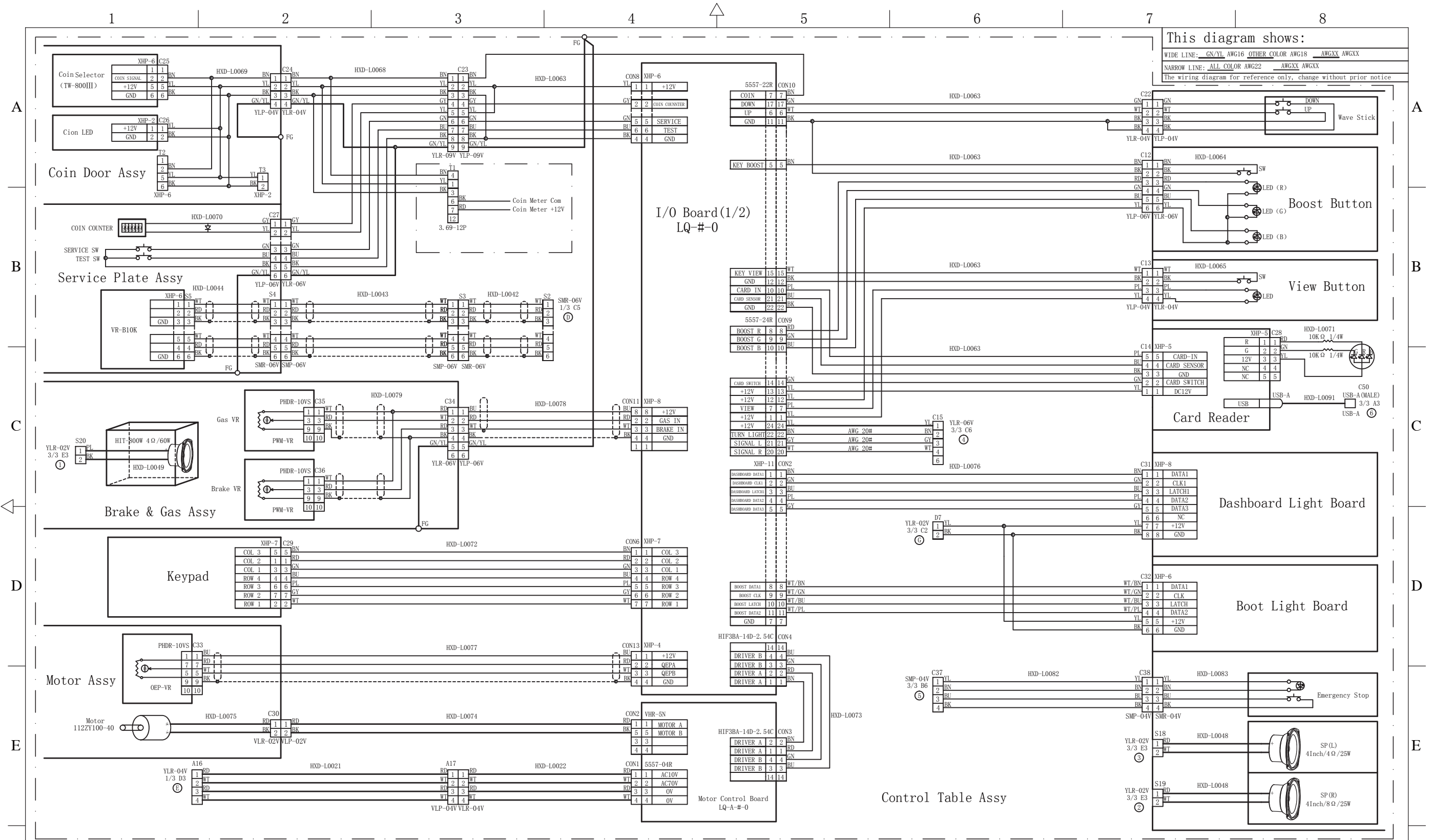

CHINESE	ENGLISH	ENGLISH ABBREVIATED	CHINESE	ENGLISH	ENGLISH ABBREVIATED	CHINESE	ENGLISH	ENGLISH ABBREVIATED
黑	BLACK	BK	粉红	PINK	PK	白紫	WHITE PURPLE	WT/PL
棕	BROWN	BN	浅蓝	LIGHT BLUE	LT BU	白灰	WHITE GRAY	WT/GY
红	RED	RD	浅绿	LIGHT GREEN	LT GN	白粉红	WHITE PINK	WT/PK
橙	ORANGE	OG	白黑	WHITE BLACK	WT/BK	白浅蓝	WHITE LIGHT BLUE	WT/LT BU
黄	YELLOW	YL	白棕	WHITE BROWN	WT/BN	白浅绿	WHITE LIGHT GREEN	WT/LT GN
绿	GREEN	GN	白红	WHITE RED	WT/RD	绿黄	GREEN YELLOW	GN/YL
蓝	BLUE	BU	白橙	WHITE ORANGE	WT/OG			
紫	PURPLE	PL	白黄	WHITE YELLOW	WT/YL			
灰	GRAY	GY	白绿	WHITE GREEN	WT/GN			
白	WHITE	WT	白蓝	WHITE BLUE	WT/BU			

This diagram shows:
 WIDE LINE: GN/YL AWG16 OTHER COLOR AWG18 AWGX AWGX
 NARROW LINE: ALL COLOR AWG22 AWGX AWGX
 The wiring diagram for reference only, change without prior notice

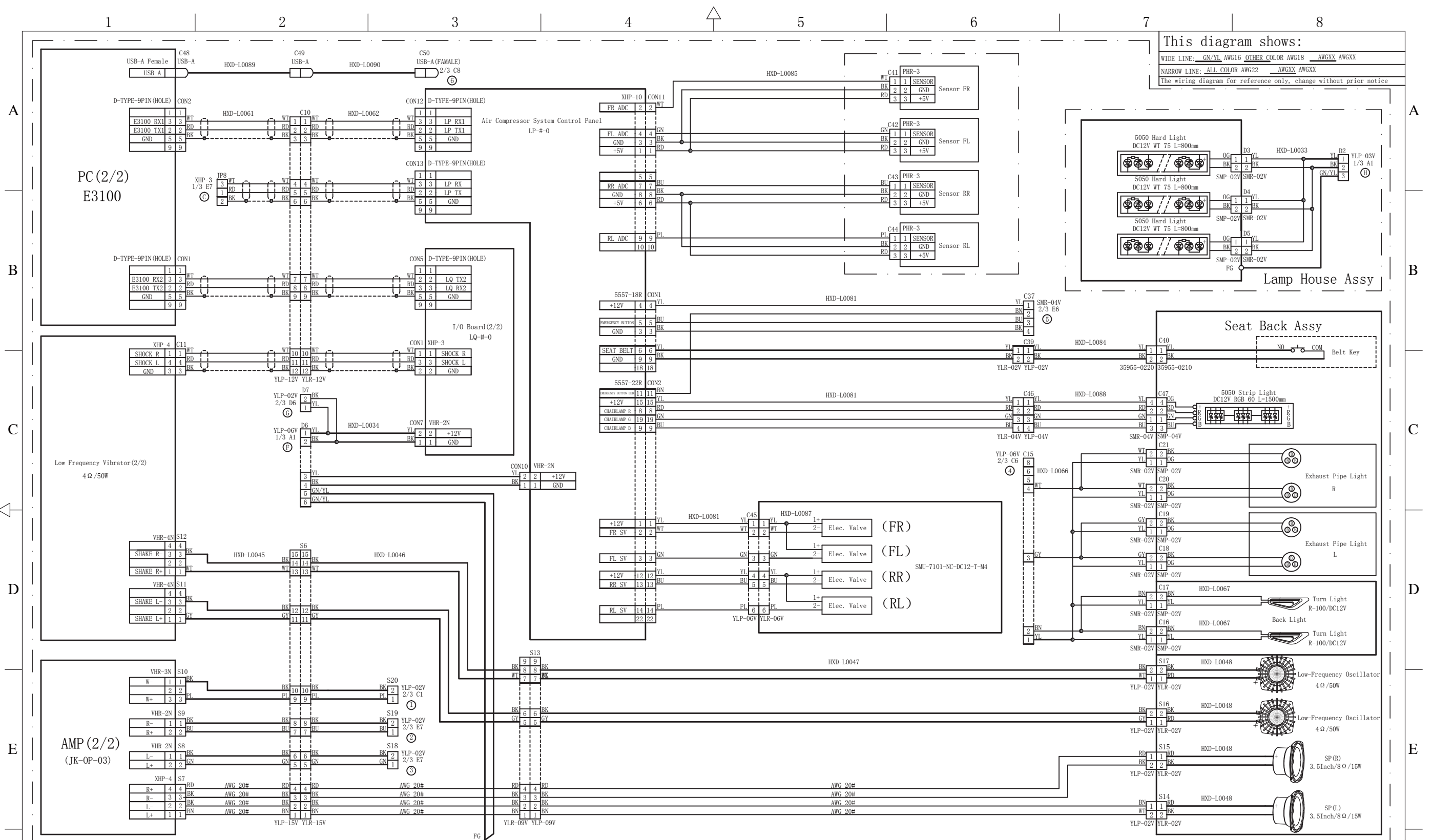

CHINESE	ENGLISH	ENGLISH ABBREVIATED	CHINESE	ENGLISH	ENGLISH ABBREVIATED	CHINESE	ENGLISH	ENGLISH ABBREVIATED
黑	BLACK	BK	粉红	PINK	PK	白紫	WHITE PURPLE	WT/PL
棕	BROWN	BN	浅蓝	LIGHT BLUE	LT BU	白灰	WHITE GRAY	WT/GY
红	RED	RD	浅绿	LIGHT GREEN	LT GN	白粉红	WHITE PINK	WT/PK
橙	ORANGE	OG	白黑	WHITE BLACK	WT/BK	白浅蓝	WHITE LIGHT BLUE	WT/LT BU
黄	YELLOW	YL	白棕	WHITE BROWN	WT/BN	白浅绿	WHITE LIGHT GREEN	WT/LT GN
绿	GREEN	GN	白红	WHITE RED	WT/RD	绿黄	GREEN YELLOW	GN/YL
蓝	BLUE	BU	白橙	WHITE ORANGE	WT/OG			
紫	PURPLE	PL	白黄	WHITE YELLOW	WT/YL			
灰	GRAY	GY	白绿	WHITE GREEN	WT/GN			
白	WHITE	WT	白蓝	WHITE BLUE	WT/BU			

After-sales Service

Honorable customer !

Thank you for purchasing our product !
For your benefits , if you find any fault during the operation of the product, please use a technician who obtains a certificate related to mechanical engineering , electrical engineering or who engages in routine maintenance , repair and management of amusement machine to check the machine and inform us the fault in a timely manner. Our company will take corresponding measures to assist you to solve the problem promptly.

NOTICE: Do not dismount or replace any part of the machine without our technician's permission, or you will solely undertake the consequence !

Please pay attention to our contact information as follow:

Guangzhou Wahlap Technology Corporation Limited

Add: H1-H6 Startoon city, Yingxing Dong Road, Donghuan Street, Panyu,
Guangzhou, China

Tel: +86 20 39226222 Fax: +86 20 39226300
Service Hotline: +86 20 39226222 4006-926-222

<http://www.wahlap.com>

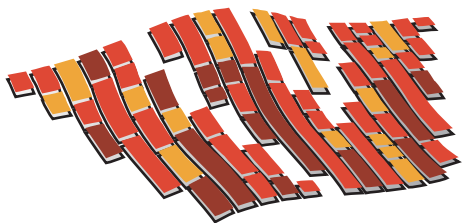

Ver.1.00

WAHLAP TECH
<http://www.wahlap.com.cn>

※ The specifications and operation instructions in this Manual are subject to change without notice for reasons such as performance.